

PHYSICS

PHYSICS B

PHYSICS C: MECHANICS

**PHYSICS C: ELECTRICITY AND
MAGNETISM**

Course Description

Effective Fall 2011

AP Course Descriptions are updated regularly. Please visit AP Central® (apcentral.collegeboard.com) to determine whether a more recent Course Description PDF is available.

The College Board

The College Board is a not-for-profit membership association whose mission is to connect students to college success and opportunity. Founded in 1900, the College Board is composed of more than 5,700 schools, colleges, universities and other educational organizations. Each year, the College Board serves seven million students and their parents, 23,000 high schools, and 3,800 colleges through major programs and services in college readiness, college admission, guidance, assessment, financial aid and enrollment. Among its widely recognized programs are the SAT[®], the PSAT/NMSQT[®], the Advanced Placement Program[®] (AP[®]), SpringBoard[®] and ACCUPLACER[®]. The College Board is committed to the principles of excellence and equity, and that commitment is embodied in all of its programs, services, activities and concerns.

For further information, visit www.collegeboard.org.

AP Equity and Access Policy

The College Board strongly encourages educators to make equitable access a guiding principle for their AP programs by giving all willing and academically prepared students the opportunity to participate in AP. We encourage the elimination of barriers that restrict access to AP for students from ethnic, racial and socioeconomic groups that have been traditionally underserved. Schools should make every effort to ensure their AP classes reflect the diversity of their student population. The College Board also believes that all students should have access to academically challenging course work before they enroll in AP classes, which can prepare them for AP success. It is only through a commitment to equitable preparation and access that true equity and excellence can be achieved.

AP Course and Exam Descriptions

AP Course and Exam Descriptions are updated regularly. Please visit AP Central[®] (apcentral.collegeboard.com) to determine whether a more recent Course and Exam Description PDF is available.

Contents

Welcome to the AP Program	1
AP Course Audit	1
AP Development Committees	2
AP Reading	2
AP Exam Scores	2
Credit and Placement for AP Scores	2
Setting Credit and Placement Policies for AP Scores	3
AP Physics	4
Introduction	4
What We Are About: A Message from the Development Committee	4
The Courses	4
Course Selection	6
Instructional Approaches	7
Laboratory	8
Importance and Rationale	8
Implementation and Recommendations	9
Documenting Laboratory Experience	10
Physics B Course	11
Physics C Courses	11
Comparison of Topics in Physics B and Physics C	12
Content Outline for Physics B and Physics C	13
Learning Objectives for AP Physics	17
The Exams	38
The Free-Response Sections — Student Presentation	39
Calculators and Equation Tables	41
Physics B Sample Multiple-Choice Questions	44
Answers to Physics B Multiple-Choice Questions	52
Physics B Sample Free-Response Questions	53
Physics C: Mechanics Sample Multiple-Choice Questions	62
Answers to Physics C: Mechanics Multiple-Choice Questions	66
Physics C: Mechanics Sample Free-Response Questions	67
Physics C: Electricity and Magnetism Sample Multiple-Choice Questions	71
Answers to Physics C: Electricity and Magnetism Multiple-Choice Questions	77
Physics C: Electricity and Magnetism Sample Free-Response Questions	78
Teacher Support	81
AP Central (apcentral.collegeboard.com)	81
Additional Resources	81

Welcome to the AP[®] Program

AP[®] is a rigorous academic program built on the commitment, passion and hard work of students and educators from both secondary schools and higher education. With more than 30 courses in a wide variety of subject areas, AP provides willing and academically prepared high school students with the opportunity to study and learn at the college level.

Through AP courses, talented and dedicated AP teachers help students develop and apply the skills, abilities and content knowledge they will need later in college. Each AP course is modeled upon a comparable college course, and college and university faculty play a vital role in ensuring that AP courses align with college-level standards. For example, through the AP Course Audit, AP teachers submit their syllabi for review and approval by college faculty. Only courses using syllabi that meet or exceed the college-level curricular and resource requirements for each AP course are authorized to carry the “AP” label.

AP courses culminate in a suite of college-level assessments developed and scored by college and university faculty members as well as experienced AP teachers. AP Exams are an essential part of the AP experience, enabling students to demonstrate their mastery of college-level course work. Strong performance on AP Exams is rewarded by colleges and universities worldwide. More than 90 percent of four-year colleges and universities in the United States grant students credit, placement or both on the basis of successful AP Exam scores. But performing well on an AP Exam means more than just the successful completion of a course; it is the gateway to success in college. Research consistently shows that students who score a 3 or higher typically experience greater academic success in college and improved graduation rates than their non-AP student peers.

AP Course Audit

The intent of the AP Course Audit is to provide secondary and higher education constituents with the assurance that an “AP” designation on a student’s transcript is credible, meaning the AP Program has authorized a course that has met or exceeded the curricular requirements and classroom resources that demonstrate the academic rigor of a comparable college course. To receive authorization from the College Board to label a course “AP,” teachers must participate in the AP Course Audit. Courses authorized to use the “AP” designation are listed in the AP Course Ledger made available to colleges and universities each fall. It is the school’s responsibility to ensure that its AP Course Ledger entry accurately reflects the AP courses offered within each academic year.

The AP Program unequivocally supports the principle that each individual school must develop its own curriculum for courses labeled “AP.” Rather than mandating any one curriculum for AP courses, the AP Course Audit instead provides each AP teacher with a set of expectations that college and secondary school faculty nationwide have established for college-level courses. AP teachers are encouraged to develop or maintain their own curriculum that either includes or exceeds each of these expectations; such courses will be authorized to use the “AP” designation. Credit for the success of AP courses belongs to the individual schools and teachers that create powerful, locally designed AP curricula.

Complete information about the AP Course Audit is available at www.collegeboard.com/apcourseaudit.

AP Development Committees

An AP Development Committee is a group of nationally renowned subject-matter experts in a particular discipline that includes professionals in secondary and postsecondary education as well as from professional organizations. These experts ensure that AP courses and exams reflect the most up-to-date information available, as befitting a college-level course, and that student proficiency is assessed properly. To find a list of current AP Development Committee members, please visit apcentral.collegeboard.com/developmentcommittees.

AP Reading

AP Exams — with the exception of AP Studio Art, which is a portfolio assessment — consist of dozens of multiple-choice questions scored by machine, and free-response questions scored at the annual AP Reading by thousands of college faculty and expert AP teachers. AP Readers use scoring standards developed by college and university faculty who teach the corresponding college course. The AP Reading offers educators both significant professional development and the opportunity to network with colleagues. For more information about the AP Reading, or to apply to serve as a Reader, visit apcentral.collegeboard.com/readers.

AP Exam Scores

The Readers' scores on the free-response questions are combined with the results of the computer-scored multiple-choice questions; the weighted raw scores are summed to give a composite score. The composite score is then converted to a score on AP's 5-point scale. While colleges and universities are responsible for setting their own credit and placement policies, AP scores signify how qualified students are to receive college credit or placement:

AP SCORE	QUALIFICATION
5	Extremely well qualified
4	Well qualified
3	Qualified
2	Possibly qualified
1	No recommendation

AP Exam scores of 5 are equivalent to A grades in the corresponding college course. AP Exam scores of 4 are equivalent to grades of A–, B+ and B in college. AP Exam scores of 3 are equivalent to grades of B–, C+ and C in college.

Credit and Placement for AP Scores

Thousands of two- and four-year colleges and universities grant credit, placement or both for qualifying AP Exam scores because these scores represent a level of

achievement equivalent to that of students who have taken the comparable college course. This college-level equivalency is ensured through several AP Program processes:

- College faculty are involved in course and exam development and other AP activities. Currently, college faculty:
 - Serve as chairs and members of the committees that develop the Course Descriptions and exams for each AP course.
 - Are responsible for standard setting and are involved in the evaluation of student responses at the annual AP Reading. The Chief Reader for each AP exam is a college faculty member.
 - Lead professional development seminars for new and experienced AP teachers.
 - Serve as the senior reviewers in the annual AP Course Audit, ensuring AP teachers' syllabi meet the curriculum guidelines for college-level courses.
- AP courses and exams are reviewed and updated regularly based on the results of curriculum surveys at up to 200 colleges and universities, collaborations among the College Board and key educational and disciplinary organizations, and the interactions of committee members with professional organizations in their discipline.
- Periodic college comparability studies are undertaken in which the performance of college students on a selection of AP Exam questions is compared with that of AP students to ensure that grades earned by college students are aligned with scores AP students earn on the exam.

For more information about the role of colleges and universities in the AP Program, visit the Value of AP to Colleges and Universities section of the College Board website at <http://professionals.collegeboard.com/higher-ed/placement/ap>.

Setting Credit and Placement Policies for AP Scores

The College Board website for education professionals has a section specifically for colleges and universities that provides guidance in setting AP credit and placement policies. Visit <http://professionals.collegeboard.com/higher-ed/placement/ap/policy>.

Additional resources, including links to AP research studies, released exam questions and sample student responses at varying levels of achievement for each AP Exam are also available. To view student samples and scoring guidelines, visit http://apcentral.collegeboard.com/apc/public/exam/exam_questions/index.html.

To review recent validity research studies, visit <http://professionals.collegeboard.com/data-reports-research/cb/ap>.

The “AP Credit Policy Info” online search tool provides links to credit and placement policies at more than 1,000 colleges and universities. This tool helps students find the credit hours and/or advanced placement they may receive for qualifying exam scores within each AP subject at a specified institution. AP Credit Policy Info is available at www.collegeboard.com/ap/creditpolicy. If the information for your institution is not listed or is incorrect, please contact aphighered@collegeboard.org.

AP Physics

INTRODUCTION

What We Are About: A Message from the Development Committee

The AP Physics Development Committee recognizes that curriculum, course content and assessment of scholastic achievement play complementary roles in shaping education at all levels. The committee believes that assessment should support and encourage the following broad instructional goals:

1. *Physics knowledge* — Basic knowledge of the discipline of physics, including phenomenology, theories and techniques, concepts and general principles
2. *Problem solving* — Ability to ask physical questions and to obtain solutions to physical questions by use of qualitative and quantitative reasoning and by experimental investigation
3. *Student attributes* — Fostering of important student attributes, including appreciation of the physical world and the discipline of physics, curiosity, creativity and reasoned skepticism
4. *Connections* — Understanding connections of physics to other disciplines and to societal issues

The first three of these goals are appropriate for the AP and introductory-level college physics courses that should, in addition, provide a background for the attainment of the fourth goal.

The AP Physics Exams have always emphasized achievement of the first two goals. Over the years, the definitions of basic knowledge of the discipline and problem solving have evolved. The AP Physics courses have reflected changes in college courses, consistent with our primary charge. We have increased our emphasis on physical intuition, experimental investigation and creativity. We include more open-ended questions in order to assess students' ability to explain their understanding of physical concepts. We structure questions that stress the use of mathematics to illuminate the physical situation rather than to show manipulative abilities.

The committee is dedicated to developing exams that can be graded fairly and consistently and that are free of ethnic, gender, economic or other bias. We operate under practical constraints of testing methods, allotted time and large numbers of students at widely spread geographical locations. In spite of these constraints, the committee strives to design exams that promote excellent and appropriate instruction in physics.

THE COURSES

The AP Physics Exams are designed to test student achievement in the AP Physics courses described in this book. These courses are intended to be representative of courses commonly offered in colleges and universities, but they do not necessarily correspond precisely to courses at any particular institution. The aim of an AP

secondary school course in physics should be to develop the students' abilities to do the following:

1. Read, understand and interpret physical information — verbal, mathematical and graphical
2. Describe and explain the sequence of steps in the analysis of a particular physical phenomenon or problem; that is,
 - a. describe the idealized model to be used in the analysis, including simplifying assumptions where necessary;
 - b. state the concepts or definitions that are applicable;
 - c. specify relevant limitations on applications of these principles;
 - d. carry out and describe the steps of the analysis, verbally or mathematically; and
 - e. interpret the results or conclusions, including discussion of particular cases of special interest
3. Use basic mathematical reasoning — arithmetic, algebraic, geometric, trigonometric, or calculus, where appropriate — in a physical situation or problem
4. Perform experiments and interpret the results of observations, including making an assessment of experimental uncertainties

In the achievement of these goals, concentration on basic principles of physics and their applications through careful and selective treatment of well-chosen areas is more important than superficial and encyclopedic coverage of many detailed topics. Within the general framework outlined on pages 13–15, teachers may exercise some freedom in the choice of topics.

In the AP Physics Exams, an attempt is made through the use of multiple-choice and free-response questions to determine how well these goals have been achieved by the student either in a conventional course or through independent study. The level of the student's achievement is assigned an AP Exam score of 1 to 5, and many colleges use this score alone as the basis for placement and credit decisions.

Introductory college physics courses typically fall into one of three categories, designated as A, B, and C in the following discussion.

Category A includes courses in which major concepts of physics are covered without as much mathematical rigor as in more formal courses, such as *Category B* and *Category C*, which are described below. The emphasis in *Category A* courses is on developing a qualitative conceptual understanding of general principles and models and on the nature of scientific inquiry. Some courses may also view physics primarily from a cultural or historical perspective. *Category A* courses are generally intended for students not majoring in a science-related field. The level of mathematical sophistication usually includes some algebra and may extend to simple trigonometry, but rarely beyond. These courses vary widely in content and approach, and at present there is no AP course or exam in this category. A high school version of a *Category A* course that concentrates on conceptual development and that provides an enriching laboratory experience may be taken by students in the ninth or tenth grade and should provide the first course in physics that prepares them for a more mathematically rigorous AP Physics B or C course.

Category B courses build on the conceptual understanding attained in a first course in physics, such as the *Category A* course described previously. These courses provide a systematic development of the main principles of physics, emphasizing problem solving and helping students develop a deep understanding of physics concepts. It is assumed that students are familiar with algebra and trigonometry, although some theoretical developments may use basic concepts of calculus. In most colleges, this is a one-year terminal course including a laboratory component and is not the usual preparation for more advanced physics and engineering courses. However, *Category B* courses often provide a foundation in physics for students in the life sciences, premedicine, and some applied sciences, as well as other fields not directly related to science. AP Physics B is intended to be equivalent to such courses.

Category C courses also build on the conceptual understanding attained in a first course in physics, such as the *Category A* course described above. These courses normally form the college sequence that serves as the foundation in physics for students majoring in the physical sciences or engineering. The sequence is parallel to or preceded by mathematics courses that include calculus. Methods of calculus are used in formulating physical principles and in applying them to physical problems. The sequence is more intensive and analytic than in *Category B* courses. Strong emphasis is placed on solving a variety of challenging problems, some requiring calculus, as well as continuing to develop a deep understanding of physics concepts. A *Category C* sequence may be a very intensive one-year course in college but often will extend over one and one-half to two years, and a laboratory component is also included. AP Physics C is intended to be equivalent to part of a *Category C* sequence and covers two major areas: mechanics, and electricity and magnetism, with equal emphasis on both.

In certain colleges and universities, other types of unusually high-level introductory courses are taken by a few selected students. Selection of students for these courses is often based on results of AP Exams, other college admission information, or a college-administered exam. The AP Exams are not designed to grant credit or exemption for such high-level courses but may facilitate admission to them.

Course Selection

It is important for those teaching and advising AP students to consider the relation of AP courses to a student's college plans. In some circumstances it is advantageous to take the AP Physics B course. The student may be interested in studying physics as a basis for more advanced work in the life sciences, medicine, geology, and related areas, or as a component in a nonscience college program that has science requirements. Credit or advanced placement for the Physics B course provides the student with an opportunity either to have an accelerated college program or to meet a basic science requirement; in either case the student's college program may be enriched. Access to an intensive physics sequence for physics or science majors is another opportunity that may be available.

For students planning to specialize in a physical science or in engineering, most colleges require an introductory physics sequence that includes courses equivalent to Physics C. Since a previous or concurrent course in calculus is often required of students taking Physics C, students who expect advanced placement or credit for

either Physics C exam should attempt an AP course in calculus as well; otherwise, placement in the next-in-sequence physics course may be delayed or even denied. Either of the AP Calculus courses, Calculus AB or Calculus BC, should provide an acceptable basis for students preparing to major in the physical sciences or engineering, but Calculus BC is recommended. Therefore, if such students must choose between AP Physics or AP Calculus while in high school, they should probably choose AP Calculus.

There are three separate AP Physics Exams, Physics B, Physics C: Mechanics and Physics C: Electricity and Magnetism. Each exam contains multiple-choice and free-response questions. The Physics B Exam is for students who have taken a Physics B course or who have mastered the material of this course through independent study. The Physics B Exam covers topics in mechanics, electricity and magnetism, fluid mechanics and thermal physics, waves and optics, and atomic and nuclear physics; a single exam score is reported. Similarly, the two Physics C Exams correspond to the Physics C course sequence. One exam covers mechanics; the other covers electricity and magnetism. Students may take either or both exams, and separate scores are reported.

Further descriptions of the AP Physics courses and their corresponding exams in terms of topics, level, mathematical rigor and typical textbooks are presented in the pages that follow. Information about organizing and conducting AP Physics courses, of interest to both beginning and experienced AP teachers, may be found on the AP Physics home pages on AP Central (apcentral.collegeboard.com). These pages include practical advice from successful AP teachers. The *2009 AP Physics B and Physics C Released Exams* book contains the complete exams, with solutions and grading standards for the free-response sections and sample student responses, as well as statistical data on student performance. For information about ordering these publications and others, see page 81.

Instructional Approaches

It is strongly recommended that both Physics B and Physics C be taught as second-year physics courses. A first-year physics course aimed at developing a thorough understanding of important physical principles and that permits students to explore concepts in the laboratory provides a richer experience in the process of science and better prepares them for the more analytical approaches taken in AP courses.

However, secondary school programs for the achievement of AP course goals can take other forms as well, and the imaginative teacher can design approaches that best fit the needs of his or her students. In some schools, AP Physics has been taught successfully as a very intensive first-year course; but in this case there may not be enough time to cover the material in sufficient depth to reinforce the students' conceptual understanding or to provide adequate laboratory experiences. This approach can work for highly motivated, able students but is not generally recommended. Independent study or other first-year physics courses supplemented with extra work for individual motivated students are also possibilities that have been successfully implemented.

If AP Physics is taught as a second-year course, it is recommended that the course meet for at least 250 minutes per week (the equivalent of a 50-minute period every day). However, if it is to be taught as a first-year course, approximately 90 minutes per day (450 minutes per week) is recommended in order to devote sufficient time to study the material to an appropriate depth and allow time for labs.

In a school that uses block scheduling, it is strongly recommended that AP Physics B be scheduled to extend over an entire year. A one-year AP course should not be taught in one semester, as this length of time is insufficient for students to properly assimilate and understand the important concepts of physics that are covered in the syllabus. Each of the Physics C courses, but not both, can be taught in one semester.

Whichever approach is taken, the nature of the AP course requires teachers to spend time on the extra preparation needed for both class and laboratory. AP teachers should have a teaching load that is adjusted accordingly.

Laboratory

Importance and Rationale

Laboratory experience must be part of the education of AP Physics students and should be included in all AP Physics courses, just as it is in introductory college physics courses. In textbooks and problems, most attention is paid to idealized situations: friction is often assumed to be constant or absent; meters read true values; heat insulators are perfect; gases follow the ideal gas equation. It is in the laboratory that the validity of these assumptions can be questioned, because there the student meets nature as it is rather than in idealized form. Consequently, AP students should be able to:

- design experiments;
- observe and measure real phenomena;
- organize, display and critically analyze data;
- analyze sources of error and determine uncertainties in measurement;
- draw inferences from observations and data; and
- communicate results, including suggested ways to improve experiments and proposed questions for further study.

Laboratory experience is also important in helping students understand the topics being considered. Thus it is valuable to ask students to write informally about what they have done, observed and concluded, as well as for them to keep well-organized laboratory notebooks.

Students need to be proficient in problem solving and in the application of fundamental principles to a wide variety of situations. Problem-solving ability can be fostered by investigations that are somewhat nonspecific. Such investigations are often more interesting and valuable than “cookbook” experiments that merely investigate a well-established relationship and can take important time away from the rest of the course.

Some questions or parts of questions on each AP Physics Exam deal with lab-related skills, such as design of experiments, data analysis and error analysis, and may distinguish between students who have had laboratory experience and those who have not. In addition, understanding gained in the laboratory may improve students' test performance overall.

Implementation and Recommendations

Laboratory programs in both college courses and AP courses differ widely, and there is no clear evidence that any one approach is necessarily best. This diversity of approaches should be encouraging to the high school teacher of an AP course. The success of a given program depends strongly on the interests and enthusiasm of the teacher and on the general ability and motivation of the students involved.

Although programs differ, the AP Physics Development Committee has made some recommendations in regard to school resources and scheduling. **Since an AP course is a college course, the equipment and time allotted to laboratories should be similar to that in a college course. Therefore, school administrators should realize the implications, in both cost and time, of incorporating serious laboratories into their program. Schools must ensure that students have access to scientific equipment and all materials necessary to conduct hands-on, college-level physics laboratory investigations as outlined in the teacher's course syllabus.**

In addition to equipment commonly included in college labs, students in AP Physics should have adequate and timely access to computers that are connected to the Internet and its many online resources. Students should also have access to computers with appropriate sensing devices and software for use in gathering, graphing and analyzing laboratory data and writing reports. Although using computers in this way is a useful activity and is encouraged, some initial experience with gathering, graphing and manipulating data by hand is also important so that students attain a better feel for the physical realities involved in the experiments. And it should be emphasized that simulating an experiment on a computer cannot adequately replace the actual, hands-on experience of doing an experiment.

Flexible or modular scheduling is best in order to meet the time requirements identified in the course outline. Some schools are able to assign daily double periods so that laboratory and quantitative problem-solving skills may be fully developed. A weekly extended or double laboratory period is recommended for labs. It is not advisable to attempt to complete high-quality AP laboratory work entirely within standard 45- to 50-minute periods.

If AP Physics is taught as a second-year physics course, the AP labs should build on and extend the lab experiences of the first-year course. The important criterion is that students completing an AP Physics course must have had laboratory experiences that are roughly equivalent to those in a comparable introductory college course.

Past surveys of introductory college physics courses, both noncalculus and calculus-based, have revealed that on average about 20 percent of the total course credit awarded can be attributed to lab performance; from two to three hours per week are typically devoted to laboratory activities. Secondary schools may have

difficulty scheduling this much weekly time for lab. However, the college academic year typically contains fewer weeks than the secondary school year, so AP teachers may be able to schedule a few more lab periods during the year than can colleges. Also, college faculty have reported that some lab time occasionally may be used for other purposes. Nevertheless, in order for AP students to have sufficient time for lab, at least one double or extended period per week is recommended for all AP Physics courses.

Laboratory activities in colleges and AP courses can involve different levels of student involvement. They can generally be classified as: (1) prescribed or “cookbook,” (2) limited investigations with some direction provided and (3) open investigations with little or no direction provided. While many college professors believe that labs in the latter two categories have more value to students, they report often being limited in their ability to institute them by large class sizes and other factors. In this respect, AP teachers often have an advantage in being able to offer more open-ended labs to their students.

In past surveys, colleges have cited use of the following techniques to assess student lab performance: lab reports, direct observation, written tests designed specifically for lab, lab-related questions on regular lecture tests, lab practical exams, and maintenance of lab notebooks. When the colleges assessed laboratory skills with written test questions, they reported attempting to assess the following skills in order of decreasing frequency: analysis of data, analysis of errors, design of experiments, and evaluation of experiments and suggestions for future investigations.

A more detailed laboratory guide is available and can be ordered through AP Central. This guide contains descriptions of a number of experiments that typify the type and level of skills that should be developed by AP students in conducting laboratory investigations. The experiments are not mandatory; they can be modified or similar experiments substituted as long as they assist the student in developing these skills. Additional suggestions for the laboratory can be found on the AP Physics course home pages on AP Central (apcentral.collegeboard.com).

Documenting Laboratory Experience

The laboratory is important for both AP and college students. Students who have had laboratory experience in high school will be in a better position to validate their AP courses as equivalent to the corresponding college courses and to undertake the laboratory work in more advanced courses with greater confidence. Most college placement policies assume that students have had laboratory experience, and students should be prepared to show evidence of their laboratory work in case the college asks for it. Such experience should be documented for the AP course by keeping a lab notebook or a portfolio of lab reports. Students should be encouraged to keep copies of this work and any other work from previous lab experience. Presenting evidence of *adequate college-level* laboratory experience to the colleges they attend, as an adjunct to their AP scores, can be very useful to students if they desire credit for or exemption from an introductory college course that includes a laboratory. Although colleges can expect that most entering AP students have been exposed to many of the same laboratory experiments performed by their own introductory students, individual consultation with students is often used to help determine the nature of their laboratory experience.

Physics B Course

The Physics B course includes topics in both classical and modern physics. A knowledge of algebra and basic trigonometry is required for the course; the basic ideas of calculus may be introduced in connection with physical concepts, such as acceleration and work. Understanding of the basic principles involved and the ability to apply these principles in the solution of problems should be the major goals of the course. Consequently, the course should utilize guided inquiry and student-centered learning to foster the development of critical thinking skills.

Physics B should provide instruction in each of the following five content areas: Newtonian mechanics, fluid mechanics and thermal physics, electricity and magnetism, waves and optics, and atomic and nuclear physics. A content outline and percentage goals for covering each major topic in the exam are on pages 13–15. A more detailed topic outline is contained in the “Learning Objectives for AP Physics,” which starts on page 17.

Many colleges and universities include additional topics in their survey courses. Some AP teachers may wish to add supplementary material to a Physics B course. Many teachers have found that a good time to do this is late in the year, after the AP Exams have been given.

The Physics B course should also include a hands-on laboratory component comparable to introductory college-level physics laboratories, with a minimum of 12 student-conducted laboratory investigations representing a variety of topics covered in the course. Each student should complete a lab notebook or portfolio of lab reports.

The school should ensure that each student has a copy of a college-level textbook (supplemented when necessary to meet the curricular requirements) for individual use inside and outside of the classroom. A link to a list of examples of acceptable textbooks can be found on the Physics B course home page on the AP Central Web site.

Physics C Courses

There are two AP Physics C courses — Physics C: Mechanics and Physics C: Electricity and Magnetism, each corresponding to approximately a semester of college work. Mechanics is typically taught first, and some AP teachers may choose to teach this course only. If both courses are taught over the course of a year, approximately equal time should be given to each. Both courses should utilize guided inquiry and student-centered learning to foster the development of critical thinking skills and should use introductory differential and integral calculus throughout the course.

Physics C: Mechanics should provide instruction in each of the following six content areas: kinematics; Newton’s laws of motion; work, energy and power; systems of particles and linear momentum; circular motion and rotation; and oscillations and gravitation.

Physics C: Electricity and Magnetism should provide instruction in each of the following five content areas: electrostatics; conductors, capacitors and dielectrics; electric circuits; magnetic fields; and electromagnetism.

Content outlines for both courses and percentage goals for covering each major topic in the exams are on pages 13–15. A more detailed topic outline is contained in the “Learning Objectives for AP Physics,” which start on page 17.

Most colleges and universities include in similar courses additional topics such as wave motion, kinetic theory and thermodynamics, optics, alternating current circuits or special relativity. Although wave motion, optics and kinetic theory and thermodynamics are usually the most commonly included, there is little uniformity among such offerings, and these topics are not included in the Physics C Exams. The Development Committee recommends that supplementary material be added to Physics C when it is possible to do so. Many teachers have found that a good time to do this is late in the year, after the AP Exams have been given.

Each Physics C course should also include a hands-on laboratory component comparable to a semester-long introductory college-level physics laboratory. Students should spend a minimum of 20 percent of instructional time engaged in hands-on laboratory work. Each student should complete a lab notebook or portfolio of lab reports.

The school should ensure that each student has a calculus-based college-level textbook (supplemented when necessary to meet the curricular requirements) for individual use inside and outside of the classroom. A link to lists of examples of acceptable textbooks can be found on the Physics C course home pages on the AP Central website.

Comparison of Topics in Physics B and Physics C

To serve as an aid for devising AP Physics courses and to more clearly identify the specifics of the exams, a detailed topical structure has been developed that relies heavily on information obtained in college surveys. The general areas of physics are subdivided into major categories on pages 13–15, and for each category the percentage goals for each exam are given. These goals should serve only as a guide and should not be construed as reflecting the proportion of course time that should be devoted to each category.

Also, for each major category, some important subtopics are listed. The checkmarks indicate the subtopics that may be covered in each exam. Questions for the exam will come from these subtopics, but not all of the subtopics will necessarily be included in every exam, just as they are not necessarily included in every AP or college course.

It should be noted that although fewer topics are covered in Physics C than in Physics B, they are covered in greater depth and with greater analytical and mathematical sophistication, including calculus applications.

Content Outline for Physics B and Physics C

A more detailed topic outline is contained in the “Learning Objectives for AP Physics,” which follow this outline.

<i>Content Area</i>	<i>Percentage Goals for Exams</i>	
	<i>Physics B</i>	<i>Physics C: Mechanics</i>
I. Newtonian Mechanics	35%	100%
A. Kinematics (including vectors, vector algebra, components of vectors, coordinate systems, displacement, velocity and acceleration)	7%	18%
1. Motion in one dimension	√	√
2. Motion in two dimensions, including projectile motion	√	√
B. Newton’s laws of motion	9%	20%
1. Static equilibrium (first law)	√	√
2. Dynamics of a single particle (second law)	√	√
3. Systems of two or more objects (third law)	√	√
C. Work, energy, power	5%	14%
1. Work and work–energy theorem	√	√
2. Forces and potential energy	√	√
3. Conservation of energy	√	√
4. Power	√	√
D. Systems of particles, linear momentum	4%	12%
1. Center of mass		√
2. Impulse and momentum	√	√
3. Conservation of linear momentum, collisions	√	√
E. Circular motion and rotation	4%	18%
1. Uniform circular motion	√	√
2. Torque and rotational statics	√	√
3. Rotational kinematics and dynamics		√
4. Angular momentum and its conservation		√
F. Oscillations and gravitation	6%	18%
1. Simple harmonic motion (dynamics and energy relationships)	√	√
2. Mass on a spring	√	√
3. Pendulum and other oscillations	√	√
4. Newton’s law of gravity	√	√
5. Orbits of planets and satellites		
a. Circular	√	√
b. General		√

<i>Content Area</i>	<u><i>Percentage Goals for Exams</i></u>	
	<i>Physics B</i>	
II. Fluid Mechanics and Thermal Physics.	15%	
A. Fluid Mechanics	6%	
1. Hydrostatic pressure	√	
2. Buoyancy	√	
3. Fluid flow continuity	√	
4. Bernoulli's equation	√	
B. Temperature and heat	2%	
1. Mechanical equivalent of heat	√	
2. Heat transfer and thermal expansion	√	
C. Kinetic theory and thermodynamics	7%	
1. Ideal gases		
a. Kinetic model	√	
b. Ideal gas law	√	
2. Laws of thermodynamics		
a. First law (including processes on pV diagrams)	√	
b. Second law (including heat engines)	√	
III. Electricity and Magnetism	25%	<i>Physics C:</i> <i>Electricity and</i> <i>Magnetism</i>
A. Electrostatics	5%	100%
1. Charge and Coulomb's law	√	√
2. Electric field and electric potential (including point charges)	√	√
3. Gauss's law		√
4. Fields and potentials of other charge distributions		√
B. Conductors, capacitors, dielectrics	4%	14%
1. Electrostatics with conductors	√	√
2. Capacitors		
a. Capacitance	√	√
b. Parallel plate	√	√
c. Spherical and cylindrical		√
3. Dielectrics		√
C. Electric circuits	7%	20%
1. Current, resistance, power	√	√
2. Steady-state direct current circuits with batteries and resistors only	√	√
3. Capacitors in circuits		
a. Steady state	√	√
b. Transients in RC circuits		√

<i>Content Area</i>	<i>Percentage Goals for Exams</i>	
	<i>Physics B</i>	<i>Physics C: Electricity and Magnetism</i>
D. Magnetic Fields	4%	20%
1. Forces on moving charges in magnetic fields	√	√
2. Forces on current-carrying wires in magnetic fields	√	√
3. Fields of long current-carrying wires	√	√
4. Biot–Savart law and Ampere’s law		√
E. Electromagnetism	5%	16%
1. Electromagnetic induction (including Faraday’s law and Lenz’s law)	√	√
2. Inductance (including LR and LC circuits)		√
3. Maxwell’s equations		√
IV. Waves and Optics	15%	
A. Wave motion (including sound)	5%	
1. Traveling waves	√	
2. Wave propagation	√	
3. Standing waves	√	
4. Superposition	√	
B. Physical optics	5%	
1. Interference and diffraction	√	
2. Dispersion of light and the electromagnetic spectrum	√	
C. Geometric optics	5%	
1. Reflection and refraction	√	
2. Mirrors	√	
3. Lenses	√	
V. Atomic and Nuclear Physics	10%	
A. Atomic physics and quantum effects	7%	
1. Photons, the photoelectric effect, Compton scattering, x-rays	√	
2. Atomic energy levels	√	
3. Wave-particle duality	√	
B. Nuclear physics	3%	
1. Nuclear reactions (including conservation of mass number and charge)	√	
2. Mass–energy equivalence	√	

Laboratory and experimental situations: Each exam will include one or more questions or parts of questions posed in a laboratory or experimental setting. These questions are classified according to the content area that provides the setting for the situation, and each content area may include such questions. These questions generally assess some understanding of content as well as experimental skills, as described on the following pages.

Miscellaneous: Each exam may include occasional questions that overlap several major topical areas or questions on miscellaneous topics such as identification of vectors and scalars, vector mathematics, graphs of functions, history of physics or contemporary topics in physics.

Learning Objectives for AP Physics

These course objectives are intended to elaborate on the content outline for Physics B and Physics C. In addition to the five major content areas of physics, objectives are included now for laboratory skills, which have become an important part of the AP Physics Exams.

The objectives listed below are generally representative of the cumulative content of recently administered exams, although no single exam can cover them all. The checkmarks indicate the objectives that may be covered in either the Physics B or Physics C Exams.

It is reasonable to expect that future exams will continue to sample primarily from among these objectives. However, there may be an occasional question that is within the scope of the included topics but is not specifically covered by one of the listed objectives. Questions may also be based on variations or combinations of these objectives, rephrasing them but still assessing the essential concepts.

The objectives listed below are continually revised to keep them as current as possible with the content outline and the coverage of the exams.

Objectives for the AP [®] Physics Courses	AP Course	
	B	C
I. NEWTONIAN MECHANICS		
A. Kinematics (including vectors, vector algebra, components of vectors, coordinate systems, displacement, velocity and acceleration)		
1. Motion in one dimension		
a) Students should understand the general relationships among position, velocity and acceleration for the motion of a particle along a straight line, so that:		
(1) Given a graph of one of the kinematic quantities, position, velocity or acceleration, as a function of time, they can recognize in what time intervals the other two are positive, negative, or zero and can identify or sketch a graph of each as a function of time.	✓	✓
(2) Given an expression for one of the kinematic quantities, position, velocity or acceleration, as a function of time, they can determine the other two as a function of time, and find when these quantities are zero or achieve their maximum and minimum values.		✓
b) Students should understand the special case of motion with constant acceleration, so they can:		
(1) Write down expressions for velocity and position as functions of time, and identify or sketch graphs of these quantities.	✓	✓
(2) Use the equations $v = v_0 + at$, $x = x_0 + v_0t + \frac{1}{2}at^2$, and $v^2 = v_0^2 + 2a(x - x_0)$ to solve problems involving one-dimensional motion with constant acceleration.	✓	✓
c) Students should know how to deal with situations in which acceleration is a specified function of velocity and time so they can write an appropriate differential equation and solve it for $v(t)$ by separation of variables, incorporating correctly a given initial value of v .		✓

Objectives for the AP [®] Physics Courses	AP Course	
	B	C
2. Motion in two dimensions, including projectile motion		
a) Students should be able to add, subtract and resolve displacement and velocity vectors, so they can:		
(1) Determine components of a vector along two specified, mutually perpendicular axes.	✓	✓
(2) Determine the net displacement of a particle or the location of a particle relative to another.	✓	✓
(3) Determine the change in velocity of a particle or the velocity of one particle relative to another.	✓	✓
b) Students should understand the general motion of a particle in two dimensions so that, given functions $x(t)$ and $y(t)$ which describe this motion, they can determine the components, magnitude and direction of the particle's velocity and acceleration as functions of time.		✓
c) Students should understand the motion of projectiles in a uniform gravitational field, so they can:		
(1) Write down expressions for the horizontal and vertical components of velocity and position as functions of time, and sketch or identify graphs of these components.	✓	✓
(2) Use these expressions in analyzing the motion of a projectile that is projected with an arbitrary initial velocity.	✓	✓
B. Newton's laws of motion		
1. Static equilibrium (first law)		
Students should be able to analyze situations in which a particle remains at rest, or moves with constant velocity, under the influence of several forces.	✓	✓
2. Dynamics of a single particle (second law)		
a) Students should understand the relation between the force that acts on an object and the resulting change in the object's velocity, so they can:		
(1) Calculate, for an object moving in one dimension, the velocity change that results when a constant force F acts over a specified time interval.	✓	✓
(2) Calculate, for an object moving in one dimension, the velocity change that results when a force $F(t)$ acts over a specified time interval.		✓
(3) Determine, for an object moving in a plane whose velocity vector undergoes a specified change over a specified time interval, the average force that acted on the object.	✓	✓
b) Students should understand how Newton's Second Law, $\Sigma \mathbf{F} = \mathbf{F}_{net} = m\mathbf{a}$, applies to an object subject to forces such as gravity, the pull of strings or contact forces, so they can:		
(1) Draw a well-labeled, free-body diagram showing all real forces that act on the object.	✓	✓
(2) Write down the vector equation that results from applying Newton's Second Law to the object, and take components of this equation along appropriate axes.	✓	✓
c) Students should be able to analyze situations in which an object moves with specified acceleration under the influence of one or more forces so they can determine the magnitude and direction of the net force, or of one of the forces that makes up the net force, such as motion up or down with constant acceleration.	✓	✓

Objectives for the AP [®] Physics Courses	AP Course	
	B	C
d) Students should understand the significance of the coefficient of friction, so they can:		
(1) Write down the relationship between the normal and frictional forces on a surface.	✓	✓
(2) Analyze situations in which an object moves along a rough inclined plane or horizontal surface.	✓	✓
(3) Analyze under what circumstances an object will start to slip, or to calculate the magnitude of the force of static friction.	✓	✓
e) Students should understand the effect of drag forces on the motion of an object, so they can:		
(1) Find the terminal velocity of an object moving vertically under the influence of a retarding force dependent on velocity.	✓	✓
(2) Describe qualitatively, with the aid of graphs, the acceleration, velocity and displacement of such a particle when it is released from rest or is projected vertically with specified initial velocity.		✓
(3) Use Newton's Second Law to write a differential equation for the velocity of the object as a function of time.		✓
(4) Use the method of separation of variables to derive the equation for the velocity as a function of time from the differential equation that follows from Newton's Second Law.		✓
(5) Derive an expression for the acceleration as a function of time for an object falling under the influence of drag forces.		✓
3. Systems of two or more objects (third law)		
a) Students should understand Newton's Third Law so that, for a given system, they can identify the force pairs and the objects on which they act, and state the magnitude and direction of each force.	✓	✓
b) Students should be able to apply Newton's Third Law in analyzing the force of contact between two objects that accelerate together along a horizontal or vertical line, or between two surfaces that slide across one another.	✓	✓
c) Students should know that the tension is constant in a light string that passes over a massless pulley and should be able to use this fact in analyzing the motion of a system of two objects joined by a string.	✓	✓
d) Students should be able to solve problems in which application of Newton's laws leads to two or three simultaneous linear equations involving unknown forces or accelerations.	✓	✓
C. Work, energy, power		
1. Work and the work-energy theorem		
a) Students should understand the definition of work, including when it is positive, negative or zero, so they can:		
(1) Calculate the work done by a specified constant force on an object that undergoes a specified displacement.	✓	✓
(2) Relate the work done by a force to the area under a graph of force as a function of position, and calculate this work in the case where the force is a linear function of position.	✓	✓
(3) Use integration to calculate the work performed by a force $F(x)$ on an object that undergoes a specified displacement in one dimension.		✓
(4) Use the scalar product operation to calculate the work performed by a specified constant force F on an object that undergoes a displacement in a plane.	✓	✓

Objectives for the AP [®] Physics Courses	AP Course	
	B	C
b) Students should understand and be able to apply the work-energy theorem, so they can:		
(1) Calculate the change in kinetic energy or speed that results from performing a specified amount of work on an object.	✓	✓
(2) Calculate the work performed by the net force, or by each of the forces that make up the net force, on an object that undergoes a specified change in speed or kinetic energy.	✓	✓
(3) Apply the theorem to determine the change in an object's kinetic energy and speed that results from the application of specified forces, or to determine the force that is required in order to bring an object to rest in a specified distance.	✓	✓
2. Forces and potential energy		
a) Students should understand the concept of a conservative force, so they can:		
(1) State alternative definitions of "conservative force" and explain why these definitions are equivalent.		✓
(2) Describe examples of conservative forces and non-conservative forces.		✓
b) Students should understand the concept of potential energy, so they can:		
(1) State the general relation between force and potential energy, and explain why potential energy can be associated only with conservative forces.		✓
(2) Calculate a potential energy function associated with a specified one-dimensional force $F(x)$.		✓
(3) Calculate the magnitude and direction of a one-dimensional force when given the potential energy function $U(x)$ for the force.		✓
(4) Write an expression for the force exerted by an ideal spring and for the potential energy of a stretched or compressed spring.	✓	✓
(5) Calculate the potential energy of one or more objects in a uniform gravitational field.	✓	✓
3. Conservation of energy		
a) Students should understand the concepts of mechanical energy and of total energy, so they can:		
(1) State and apply the relation between the work performed on an object by non-conservative forces and the change in an object's mechanical energy.		✓
(2) Describe and identify situations in which mechanical energy is converted to other forms of energy.	✓	✓
(3) Analyze situations in which an object's mechanical energy is changed by friction or by a specified externally applied force.	✓	✓
b) Students should understand conservation of energy, so they can:		
(1) Identify situations in which mechanical energy is or is not conserved.	✓	✓
(2) Apply conservation of energy in analyzing the motion of systems of connected objects, such as an Atwood's machine.	✓	✓
(3) Apply conservation of energy in analyzing the motion of objects that move under the influence of springs.	✓	✓
(4) Apply conservation of energy in analyzing the motion of objects that move under the influence of other non-constant one-dimensional forces.		✓
c) Students should be able to recognize and solve problems that call for application both of conservation of energy and Newton's Laws.		✓

Objectives for the AP [®] Physics Courses	AP Course	
	B	C
4. Power Students should understand the definition of power, so they can:		
a) Calculate the power required to maintain the motion of an object with constant acceleration (e.g., to move an object along a level surface, to raise an object at a constant rate, or to overcome friction for an object that is moving at a constant speed).	✓	✓
b) Calculate the work performed by a force that supplies constant power, or the average power supplied by a force that performs a specified amount of work.	✓	✓
D. Systems of particles, linear momentum		
1. Center of mass		
a) Students should understand the technique for finding center of mass, so they can:		
(1) Identify by inspection the center of mass of a symmetrical object.		✓
(2) Locate the center of mass of a system consisting of two such objects.		✓
(3) Use integration to find the center of mass of a thin rod of non-uniform density		✓
b) Students should be able to understand and apply the relation between center-of-mass velocity and linear momentum, and between center-of-mass acceleration and net external force for a system of particles.		✓
c) Students should be able to define center of gravity and to use this concept to express the gravitational potential energy of a rigid object in terms of the position of its center of mass.		✓
2. Impulse and momentum Students should understand impulse and linear momentum, so they can:		
a) Relate mass, velocity, and linear momentum for a moving object, and calculate the total linear momentum of a system of objects.	✓	✓
b) Relate impulse to the change in linear momentum and the average force acting on an object.	✓	✓
c) State and apply the relations between linear momentum and center-of-mass motion for a system of particles.		✓
d) Calculate the area under a force versus time graph and relate it to the change in momentum of an object.	✓	✓
e) Calculate the change in momentum of an object given a function $F(t)$ for the net force acting on the object.		✓
3. Conservation of linear momentum, collisions		
a) Students should understand linear momentum conservation, so they can:		
(1) Explain how linear momentum conservation follows as a consequence of Newton's Third Law for an isolated system.		✓
(2) Identify situations in which linear momentum, or a component of the linear momentum vector, is conserved.	✓	✓
(3) Apply linear momentum conservation to one-dimensional elastic and inelastic collisions and two-dimensional completely inelastic collisions.	✓	✓
(4) Apply linear momentum conservation to two-dimensional elastic and inelastic collisions.		✓
(5) Analyze situations in which two or more objects are pushed apart by a spring or other agency, and calculate how much energy is released in such a process.	✓	✓

Objectives for the AP [®] Physics Courses	AP Course	
	B	C
b) Students should understand frames of reference, so they can:		
(1) Analyze the uniform motion of an object relative to a moving medium such as a flowing stream.		✓
(2) Analyze the motion of particles relative to a frame of reference that is accelerating horizontally or vertically at a uniform rate.		✓
E. Circular motion and rotation		
1. Uniform circular motion		
Students should understand the uniform circular motion of a particle, so they can:		
a) Relate the radius of the circle and the speed or rate of revolution of the particle to the magnitude of the centripetal acceleration.	✓	✓
b) Describe the direction of the particle's velocity and acceleration at any instant during the motion.	✓	✓
c) Determine the components of the velocity and acceleration vectors at any instant, and sketch or identify graphs of these quantities.	✓	✓
d) Analyze situations in which an object moves with specified acceleration under the influence of one or more forces so they can determine the magnitude and direction of the net force, or of one of the forces that makes up the net force, in situations such as the following:		
(1) Motion in a horizontal circle (e.g., mass on a rotating merry-go-round, or car rounding a banked curve).	✓	✓
(2) Motion in a vertical circle (e.g., mass swinging on the end of a string, cart rolling down a curved track, rider on a Ferris wheel).	✓	✓
2. Torque and rotational statics		
a) Students should understand the concept of torque, so they can:		
(1) Calculate the magnitude and direction of the torque associated with a given force.	✓	✓
(2) Calculate the torque on a rigid object due to gravity.	✓	✓
b) Students should be able to analyze problems in statics, so they can:		
(1) State the conditions for translational and rotational equilibrium of a rigid object.	✓	✓
(2) Apply these conditions in analyzing the equilibrium of a rigid object under the combined influence of a number of coplanar forces applied at different locations.	✓	✓
c) Students should develop a qualitative understanding of rotational inertia, so they can:		
(1) Determine by inspection which of a set of symmetrical objects of equal mass has the greatest rotational inertia.		✓
(2) Determine by what factor an object's rotational inertia changes if all its dimensions are increased by the same factor.		✓
d) Students should develop skill in computing rotational inertia so they can find the rotational inertia of:		
(1) A collection of point masses lying in a plane about an axis perpendicular to the plane.		✓
(2) A thin rod of uniform density, about an arbitrary axis perpendicular to the rod.		✓
(3) A thin cylindrical shell about its axis, or an object that may be viewed as being made up of coaxial shells.		✓
e) Students should be able to state and apply the parallel-axis theorem.		✓

Objectives for the AP [®] Physics Courses	AP Course	
	B	C
3. Rotational kinematics and dynamics		
a) Students should understand the analogy between translational and rotational kinematics so they can write and apply relations among the angular acceleration, angular velocity, and angular displacement of an object that rotates about a fixed axis with constant angular acceleration.		✓
b) Students should be able to use the right-hand rule to associate an angular velocity vector with a rotating object.		✓
c) Students should understand the dynamics of fixed-axis rotation, so they can:		
(1) Describe in detail the analogy between fixed-axis rotation and straight-line translation.		✓
(2) Determine the angular acceleration with which a rigid object is accelerated about a fixed axis when subjected to a specified external torque or force.		✓
(3) Determine the radial and tangential acceleration of a point on a rigid object.		✓
(4) Apply conservation of energy to problems of fixed-axis rotation.		✓
(5) Analyze problems involving strings and massive pulleys.		✓
d) Students should understand the motion of a rigid object along a surface, so they can:		
(1) Write down, justify and apply the relation between linear and angular velocity, or between linear and angular acceleration, for an object of circular cross-section that rolls without slipping along a fixed plane, and determine the velocity and acceleration of an arbitrary point on such an object.		✓
(2) Apply the equations of translational and rotational motion simultaneously in analyzing rolling with slipping.		✓
(3) Calculate the total kinetic energy of an object that is undergoing both translational and rotational motion, and apply energy conservation in analyzing such motion.		✓
4. Angular momentum and its conservation		
a) Students should be able to use the vector product and the right-hand rule, so they can:		
(1) Calculate the torque of a specified force about an arbitrary origin.		✓
(2) Calculate the angular momentum vector for a moving particle.		✓
(3) Calculate the angular momentum vector for a rotating rigid object in simple cases where this vector lies parallel to the angular velocity vector.		✓
b) Students should understand angular momentum conservation, so they can:		
(1) Recognize the conditions under which the law of conservation is applicable and relate this law to one- and two-particle systems such as satellite orbits.		✓
(2) State the relation between net external torque and angular momentum, and identify situations in which angular momentum is conserved.		✓
(3) Analyze problems in which the moment of inertia of an object is changed as it rotates freely about a fixed axis.		✓
(4) Analyze a collision between a moving particle and a rigid object that can rotate about a fixed axis or about its center of mass.		✓
F. Oscillations and Gravitation		
1. Simple harmonic motion (dynamics and energy relationships)		
Students should understand simple harmonic motion, so they can:		
a) Sketch or identify a graph of displacement as a function of time, and determine from such a graph the amplitude, period and frequency of the motion.	✓	✓

Objectives for the AP [®] Physics Courses	AP Course	
	B	C
b) Write down an appropriate expression for displacement of the form $A \sin \omega t$ or $A \cos \omega t$ to describe the motion.	✓	✓
c) Find an expression for velocity as a function of time.		✓
d) State the relations between acceleration, velocity and displacement, and identify points in the motion where these quantities are zero or achieve their greatest positive and negative values.	✓	✓
e) State and apply the relation between frequency and period.	✓	✓
f) Recognize that a system that obeys a differential equation of the form $d^2x/dt^2 = -\omega^2x$ must execute simple harmonic motion, and determine the frequency and period of such motion.		✓
g) State how the total energy of an oscillating system depends on the amplitude of the motion, sketch or identify a graph of kinetic or potential energy as a function of time, and identify points in the motion where this energy is all potential or all kinetic.	✓	✓
h) Calculate the kinetic and potential energies of an oscillating system as functions of time, sketch or identify graphs of these functions, and prove that the sum of kinetic and potential energy is constant.	✓	✓
i) Calculate the maximum displacement or velocity of a particle that moves in simple harmonic motion with specified initial position and velocity.		✓
j) Develop a qualitative understanding of resonance so they can identify situations in which a system will resonate in response to a sinusoidal external force.		✓
2. Mass on a spring Students should be able to apply their knowledge of simple harmonic motion to the case of a mass on a spring, so they can:		
a) Derive the expression for the period of oscillation of a mass on a spring.		✓
b) Apply the expression for the period of oscillation of a mass on a spring.	✓	✓
c) Analyze problems in which a mass hangs from a spring and oscillates vertically.	✓	✓
d) Analyze problems in which a mass attached to a spring oscillates horizontally.	✓	✓
e) Determine the period of oscillation for systems involving series or parallel combinations of identical springs, or springs of differing lengths.		✓
3. Pendulum and other oscillations Students should be able to apply their knowledge of simple harmonic motion to the case of a pendulum, so they can:		
a) Derive the expression for the period of a simple pendulum.		✓
b) Apply the expression for the period of a simple pendulum.	✓	✓
c) State what approximation must be made in deriving the period.	✓	✓
d) Analyze the motion of a torsional pendulum or physical pendulum in order to determine the period of small oscillations.		✓
4. Newton's law of gravity Students should know Newton's Law of Universal Gravitation, so they can:		
a) Determine the force that one spherically symmetrical mass exerts on another.	✓	✓
b) Determine the strength of the gravitational field at a specified point outside a spherically symmetrical mass.	✓	✓
c) Describe the gravitational force inside and outside a uniform sphere, and calculate how the field at the surface depends on the radius and density of the sphere.		✓

Objectives for the AP [®] Physics Courses	AP Course	
	B	C
5. Orbits of planets and satellites Students should understand the motion of an object in orbit under the influence of gravitational forces, so they can:		
a) For a circular orbit:		
(1) Recognize that the motion does not depend on the object's mass; describe qualitatively how the velocity, period of revolution and centripetal acceleration depend upon the radius of the orbit; and derive expressions for the velocity and period of revolution in such an orbit.	✓	✓
(2) Derive Kepler's Third Law for the case of circular orbits.	✓	✓
(3) Derive and apply the relations among kinetic energy, potential energy and total energy for such an orbit.		✓
b) For a general orbit:		
(1) State Kepler's three laws of planetary motion and use them to describe in qualitative terms the motion of an object in an elliptical orbit.		✓
(2) Apply conservation of angular momentum to determine the velocity and radial distance at any point in the orbit.		✓
(3) Apply angular momentum conservation and energy conservation to relate the speeds of an object at the two extremes of an elliptical orbit.		✓
(4) Apply energy conservation in analyzing the motion of an object that is projected straight up from a planet's surface or that is projected directly toward the planet from far above the surface.		✓
II. FLUID MECHANICS AND THERMAL PHYSICS		
A. Fluid Mechanics		
1. Hydrostatic pressure Students should understand the concept of pressure as it applies to fluids, so they can:		
a) Apply the relationship between pressure, force and area.	✓	
b) Apply the principle that a fluid exerts pressure in all directions.	✓	
c) Apply the principle that a fluid at rest exerts pressure perpendicular to any surface that it contacts.	✓	
d) Determine locations of equal pressure in a fluid.	✓	
e) Determine the values of absolute and gauge pressure for a particular situation.	✓	
f) Apply the relationship between pressure and depth in a liquid, $\Delta P = \rho g \Delta h$.	✓	
2. Buoyancy Students should understand the concept of buoyancy, so they can:		
a) Determine the forces on an object immersed partly or completely in a liquid.	✓	
b) Apply Archimedes' principle to determine buoyant forces and densities of solids and liquids.	✓	
3. Fluid flow continuity Students should understand the equation of continuity so that they can apply it to fluids in motion.	✓	
4. Bernoulli's equation Students should understand Bernoulli's equation so that they can apply it to fluids in motion.	✓	

Objectives for the AP [®] Physics Courses	AP Course	
	B	C
B. Temperature and heat		
1. Mechanical equivalent of heat Students should understand the “mechanical equivalent of heat” so they can determine how much heat can be produced by the performance of a specified quantity of mechanical work.	✓	
2. Heat transfer and thermal expansion Students should understand heat transfer and thermal expansion, so they can:		
a) Calculate how the flow of heat through a slab of material is affected by changes in the thickness or area of the slab, or the temperature difference between the two faces of the slab.	✓	
b) Analyze what happens to the size and shape of an object when it is heated.	✓	
c) Analyze qualitatively the effects of conduction, radiation and convection in thermal processes.	✓	
C. Kinetic theory and thermodynamics		
1. Ideal gases		
a) Students should understand the kinetic theory model of an ideal gas, so they can:		
(1) State the assumptions of the model.	✓	
(2) State the connection between temperature and mean translational kinetic energy, and apply it to determine the mean speed of gas molecules as a function of their mass and the temperature of the gas.	✓	
(3) State the relationship among Avogadro’s number, Boltzmann’s constant, and the gas constant R , and express the energy of a mole of a monatomic ideal gas as a function of its temperature.	✓	
(4) Explain qualitatively how the model explains the pressure of a gas in terms of collisions with the container walls, and explain how the model predicts that, for fixed volume, pressure must be proportional to temperature.	✓	
b) Students should know how to apply the ideal gas law and thermodynamic principles, so they can:		
(1) Relate the pressure and volume of a gas during an isothermal expansion or compression.	✓	
(2) Relate the pressure and temperature of a gas during constant-volume heating or cooling, or the volume and temperature during constant-pressure heating or cooling.	✓	
(3) Calculate the work performed on or by a gas during an expansion or compression at constant pressure.	✓	
(4) Understand the process of adiabatic expansion or compression of a gas.	✓	
(5) Identify or sketch on a PV diagram the curves that represent each of the above processes.	✓	
2. Laws of thermodynamics		
a) Students should know how to apply the first law of thermodynamics, so they can:		
(1) Relate the heat absorbed by a gas, the work performed by the gas and the internal energy change of the gas for any of the processes above.	✓	
(2) Relate the work performed by a gas in a cyclic process to the area enclosed by a curve on a PV diagram.	✓	
b) Students should understand the second law of thermodynamics, the concept of entropy, and heat engines and the Carnot cycle, so they can:		
(1) Determine whether entropy will increase, decrease or remain the same during a particular situation.	✓	

Objectives for the AP [®] Physics Courses	AP Course	
	B	C
(2) Compute the maximum possible efficiency of a heat engine operating between two given temperatures.	✓	
(3) Compute the actual efficiency of a heat engine.	✓	
(4) Relate the heats exchanged at each thermal reservoir in a Carnot cycle to the temperatures of the reservoirs.	✓	
III. ELECTRICITY AND MAGNETISM		
A. Electrostatics		
1. Charge and Coulomb's Law		
a) Students should understand the concept of electric charge, so they can:		
(1) Describe the types of charge and the attraction and repulsion of charges.	✓	✓
(2) Describe polarization and induced charges.	✓	✓
b) Students should understand Coulomb's Law and the principle of superposition, so they can:		
(1) Calculate the magnitude and direction of the force on a positive or negative charge due to other specified point charges.	✓	✓
(2) Analyze the motion of a particle of specified charge and mass under the influence of an electrostatic force.	✓	✓
2. Electric field and electric potential (including point charges)		
a) Students should understand the concept of electric field, so they can:		
(1) Define it in terms of the force on a test charge.	✓	✓
(2) Describe and calculate the electric field of a single point charge.	✓	✓
(3) Calculate the magnitude and direction of the electric field produced by two or more point charges.	✓	✓
(4) Calculate the magnitude and direction of the force on a positive or negative charge placed in a specified field.	✓	✓
(5) Interpret an electric field diagram.	✓	✓
(6) Analyze the motion of a particle of specified charge and mass in a uniform electric field.	✓	✓
b) Students should understand the concept of electric potential, so they can:		
(1) Determine the electric potential in the vicinity of one or more point charges.	✓	✓
(2) Calculate the electrical work done on a charge or use conservation of energy to determine the speed of a charge that moves through a specified potential difference.	✓	✓
(3) Determine the direction and approximate magnitude of the electric field at various positions given a sketch of equipotentials.	✓	✓
(4) Calculate the potential difference between two points in a uniform electric field, and state which point is at the higher potential.	✓	✓
(5) Calculate how much work is required to move a test charge from one location to another in the field of fixed point charges.	✓	✓
(6) Calculate the electrostatic potential energy of a system of two or more point charges, and calculate how much work is required to establish the charge system.	✓	✓
(7) Use integration to determine electric potential difference between two points on a line, given electric field strength as a function of position along that line.		✓
(8) State the general relationship between field and potential, and define and apply the concept of a conservative electric field.		✓

Objectives for the AP [®] Physics Courses	AP Course	
	B	C
3. Gauss's law		
a) Students should understand the relationship between electric field and electric flux, so they can:		
(1) Calculate the flux of an electric field through an arbitrary surface or of a field uniform in magnitude over a Gaussian surface and perpendicular to it.		✓
(2) Calculate the flux of the electric field through a rectangle when the field is perpendicular to the rectangle and a function of one coordinate only.		✓
(3) State and apply the relationship between flux and lines of force.		✓
b) Students should understand Gauss's Law, so they can:		
(1) State the law in integral form, and apply it qualitatively to relate flux and electric charge for a specified surface.		✓
(2) Apply the law, along with symmetry arguments, to determine the electric field for a planar, spherical or cylindrically symmetric charge distribution.		✓
(3) Apply the law to determine the charge density or total charge on a surface in terms of the electric field near the surface.		✓
4. Fields and potentials of other charge distributions		
a) Students should be able to use the principle of superposition to calculate by integration:		
(1) The electric field of a straight, uniformly charged wire.		✓
(2) The electric field and potential on the axis of a thin ring of charge, or at the center of a circular arc of charge.		✓
(3) The electric potential on the axis of a uniformly charged disk.		✓
b) Students should know the fields of highly symmetric charge distributions, so they can:		
(1) Identify situations in which the direction of the electric field produced by a charge distribution can be deduced from symmetry considerations.		✓
(2) Describe qualitatively the patterns and variation with distance of the electric field of:		
(a) Oppositely-charged parallel plates.		✓
(b) A long, uniformly-charged wire, or thin cylindrical or spherical shell.		✓
(3) Use superposition to determine the fields of parallel charged planes, coaxial cylinders or concentric spheres.		✓
(4) Derive expressions for electric potential as a function of position in the above cases.		✓
B. Conductors, capacitors, dielectrics		
1. Electrostatics with conductors		
a) Students should understand the nature of electric fields in and around conductors, so they can:		
(1) Explain the mechanics responsible for the absence of electric field inside a conductor, and know that all excess charge must reside on the surface of the conductor.	✓	✓
(2) Explain why a conductor must be an equipotential, and apply this principle in analyzing what happens when conductors are connected by wires.	✓	✓
(3) Show that all excess charge on a conductor must reside on its surface and that the field outside the conductor must be perpendicular to the surface.		✓
b) Students should be able to describe and sketch a graph of the electric field and potential inside and outside a charged conducting sphere.	✓	✓

Objectives for the AP [®] Physics Courses	AP Course	
	B	C
c) Students should understand induced charge and electrostatic shielding, so they can:		
(1) Describe the process of charging by induction.	✓	✓
(2) Explain why a neutral conductor is attracted to a charged object.	✓	✓
(3) Explain why there can be no electric field in a charge-free region completely surrounded by a single conductor, and recognize consequences of this result.		✓
(4) Explain why the electric field outside a closed conducting surface cannot depend on the precise location of charge in the space enclosed by the conductor, and identify consequences of this result.		✓
2. Capacitors		
a) Students should understand the definition and function of capacitance, so they can:		
(1) Relate stored charge and voltage for a capacitor.	✓	✓
(2) Relate voltage, charge and stored energy for a capacitor.	✓	✓
(3) Recognize situations in which energy stored in a capacitor is converted to other forms.	✓	✓
b) Students should understand the physics of the parallel-plate capacitor, so they can:		
(1) Describe the electric field inside the capacitor, and relate the strength of this field to the potential difference between the plates and the plate separation.	✓	✓
(2) Relate the electric field to the density of the charge on the plates.		✓
(3) Derive an expression for the capacitance of a parallel-plate capacitor.		✓
(4) Determine how changes in dimension will affect the value of the capacitance.	✓	✓
(5) Derive and apply expressions for the energy stored in a parallel-plate capacitor and for the energy density in the field between the plates.		✓
(6) Analyze situations in which capacitor plates are moved apart or moved closer together, or in which a conducting slab is inserted between capacitor plates, either with a battery connected between the plates or with the charge on the plates held fixed.		✓
c) Students should understand cylindrical and spherical capacitors, so they can:		
(1) Describe the electric field inside each.		✓
(2) Derive an expression for the capacitance of each.		✓
3. Dielectrics		
Students should understand the behavior of dielectrics, so they can:		
a) Describe how the insertion of a dielectric between the plates of a charged parallel-plate capacitor affects its capacitance and the field strength and voltage between the plates.		✓
b) Analyze situations in which a dielectric slab is inserted between the plates of a capacitor.		✓
C. Electric circuits		
1. Current, resistance, power		
a) Students should understand the definition of electric current, so they can relate the magnitude and direction of the current to the rate of flow of positive and negative charge.	✓	✓
b) Students should understand conductivity, resistivity and resistance, so they can:		
(1) Relate current and voltage for a resistor.	✓	✓
(2) Write the relationship between electric field strength and current density in a conductor, and describe, in terms of the drift velocity of electrons, why such a relationship is plausible.		✓

Objectives for the AP [®] Physics Courses	AP Course	
	B	C
(3) Describe how the resistance of a resistor depends upon its length and cross-sectional area, and apply this result in comparing current flow in resistors of different material or different geometry.	✓	✓
(4) Derive an expression for the resistance of a resistor of uniform cross-section in terms of its dimensions and the resistivity of the material from which it is constructed.		✓
(5) Derive expressions that relate the current, voltage and resistance to the rate at which heat is produced when current passes through a resistor.		✓
(6) Apply the relationships for the rate of heat production in a resistor.	✓	✓
2. Steady-state direct current circuits with batteries and resistors only		
a) Students should understand the behavior of series and parallel combinations of resistors, so they can:		
(1) Identify on a circuit diagram whether resistors are in series or in parallel.	✓	✓
(2) Determine the ratio of the voltages across resistors connected in series or the ratio of the currents through resistors connected in parallel.	✓	✓
(3) Calculate the equivalent resistance of a network of resistors that can be broken down into series and parallel combinations.	✓	✓
(4) Calculate the voltage, current and power dissipation for any resistor in such a network of resistors connected to a single power supply.	✓	✓
(5) Design a simple series-parallel circuit that produces a given current through and potential difference across one specified component, and draw a diagram for the circuit using conventional symbols.	✓	✓
b) Students should understand the properties of ideal and real batteries, so they can:		
(1) Calculate the terminal voltage of a battery of specified emf and internal resistance from which a known current is flowing.	✓	✓
(2) Calculate the rate at which a battery is supplying energy to a circuit or is being charged up by a circuit.		✓
c) Students should be able to apply Ohm's law and Kirchhoff's rules to direct-current circuits, in order to:		
(1) Determine a single unknown current, voltage or resistance.	✓	✓
(2) Set up and solve simultaneous equations to determine two unknown currents.		✓
d) Students should understand the properties of voltmeters and ammeters, so they can:		
(1) State whether the resistance of each is high or low.	✓	✓
(2) Identify or show correct methods of connecting meters into circuits in order to measure voltage or current.	✓	✓
(3) Assess qualitatively the effect of finite meter resistance on a circuit into which these meters are connected.		✓
3. Capacitors in circuits		
a) Students should understand the $t = 0$ and steady-state behavior of capacitors connected in series or in parallel, so they can:		
(1) Calculate the equivalent capacitance of a series or parallel combination.	✓	✓
(2) Describe how stored charge is divided between capacitors connected in parallel.	✓	✓
(3) Determine the ratio of voltages for capacitors connected in series.	✓	✓
(4) Calculate the voltage or stored charge, under steady-state conditions, for a capacitor connected to a circuit consisting of a battery and resistors.	✓	✓

Objectives for the AP [®] Physics Courses	AP Course	
	B	C
b) Students should understand the discharging or charging of a capacitor through a resistor, so they can:		
(1) Calculate and interpret the time constant of the circuit.		✓
(2) Sketch or identify graphs of stored charge or voltage for the capacitor, or of current or voltage for the resistor, and indicate on the graph the significance of the time constant.		✓
(3) Write expressions to describe the time dependence of the stored charge or voltage for the capacitor, or of the current or voltage for the resistor.		✓
(4) Analyze the behavior of circuits containing several capacitors and resistors, including analyzing or sketching graphs that correctly indicate how voltages and currents vary with time.		✓
D. Magnetic Fields		
1. Forces on moving charges in magnetic fields		
Students should understand the force experienced by a charged particle in a magnetic field, so they can:		
a) Calculate the magnitude and direction of the force in terms of q , \mathbf{v} , and \mathbf{B} , and explain why the magnetic force can perform no work.	✓	✓
b) Deduce the direction of a magnetic field from information about the forces experienced by charged particles moving through that field.	✓	✓
c) Describe the paths of charged particles moving in uniform magnetic fields.	✓	✓
d) Derive and apply the formula for the radius of the circular path of a charge that moves perpendicular to a uniform magnetic field.	✓	✓
e) Describe under what conditions particles will move with constant velocity through crossed electric and magnetic fields.	✓	✓
2. Forces on current-carrying wires in magnetic fields		
Students should understand the force exerted on a current-carrying wire in a magnetic field, so they can:		
a) Calculate the magnitude and direction of the force on a straight segment of current-carrying wire in a uniform magnetic field.	✓	✓
b) Indicate the direction of magnetic forces on a current-carrying loop of wire in a magnetic field, and determine how the loop will tend to rotate as a consequence of these forces.	✓	✓
c) Calculate the magnitude and direction of the torque experienced by a rectangular loop of wire carrying a current in a magnetic field.		✓
3. Fields of long current-carrying wires		
Students should understand the magnetic field produced by a long straight current-carrying wire, so they can:		
a) Calculate the magnitude and direction of the field at a point in the vicinity of such a wire.	✓	✓
b) Use superposition to determine the magnetic field produced by two long wires.	✓	✓
c) Calculate the force of attraction or repulsion between two long current-carrying wires.	✓	✓
4. Biot-Savart law and Ampere's law		
a) Students should understand the Biot-Savart Law, so they can:		
(1) Deduce the magnitude and direction of the contribution to the magnetic field made by a short straight segment of current-carrying wire.		✓
(2) Derive and apply the expression for the magnitude of \mathbf{B} on the axis of a circular loop of current.		✓

Objectives for the AP [®] Physics Courses	AP Course	
	B	C
b) Students should understand the statement and application of Ampere's Law in integral form, so they can:		
(1) State the law precisely.		✓
(2) Use Ampere's law, plus symmetry arguments and the right-hand rule, to relate magnetic field strength to current for planar or cylindrical symmetries.		✓
c) Students should be able to apply the superposition principle so they can determine the magnetic field produced by combinations of the configurations listed above.		✓
E. Electromagnetism		
1. Electromagnetic induction (including Faraday's law and Lenz's law)		
a) Students should understand the concept of magnetic flux, so they can:		
(1) Calculate the flux of a uniform magnetic field through a loop of arbitrary orientation.	✓	✓
(2) Use integration to calculate the flux of a non-uniform magnetic field, whose magnitude is a function of one coordinate, through a rectangular loop perpendicular to the field.		✓
b) Students should understand Faraday's law and Lenz's law, so they can:		
(1) Recognize situations in which changing flux through a loop will cause an induced emf or current in the loop.	✓	✓
(2) Calculate the magnitude and direction of the induced emf and current in a loop of wire or a conducting bar under the following conditions:		
(a) The magnitude of a related quantity such as magnetic field or area of the loop is changing at a constant rate.	✓	✓
(b) The magnitude of a related quantity such as magnetic field or area of the loop is a specified non-linear function of time.		✓
c) Students should be able to analyze the forces that act on induced currents so they can determine the mechanical consequences of those forces.		✓
2. Inductance (including LR and LC circuits)		
a) Students should understand the concept of inductance, so they can:		
(1) Calculate the magnitude and sense of the emf in an inductor through which a specified changing current is flowing.		✓
(2) Derive and apply the expression for the self-inductance of a long solenoid.		✓
b) Students should understand the transient and steady state behavior of DC circuits containing resistors and inductors, so they can:		
(1) Apply Kirchhoff's rules to a simple LR series circuit to obtain a differential equation for the current as a function of time.		✓
(2) Solve the differential equation obtained in (1) for the current as a function of time through the battery, using separation of variables.		✓
(3) Calculate the initial transient currents and final steady state currents through any part of a simple series and parallel circuit containing an inductor and one or more resistors.		✓
(4) Sketch graphs of the current through or voltage across the resistors or inductor in a simple series and parallel circuit.		✓
(5) Calculate the rate of change of current in the inductor as a function of time.		✓
(6) Calculate the energy stored in an inductor that has a steady current flowing through it.		✓
3. Maxwell's equations		
Students should be familiar with Maxwell's equations so they can associate each equation with its implications.		✓

Objectives for the AP [®] Physics Courses	AP Course	
	B	C
IV. WAVES AND OPTICS		
A. Wave motion (including sound)		
1. Traveling waves Students should understand the description of traveling waves, so they can:		
a) Sketch or identify graphs that represent traveling waves and determine the amplitude, wavelength and frequency of a wave from such a graph.	✓	
b) Apply the relation among wavelength, frequency and velocity for a wave.	✓	
c) Understand qualitatively the Doppler effect for sound in order to explain why there is a frequency shift in both the moving-source and moving-observer case.	✓	
d) Describe reflection of a wave from the fixed or free end of a string.	✓	
e) Describe qualitatively what factors determine the speed of waves on a string and the speed of sound.	✓	
2. Wave propagation		
a) Students should understand the difference between transverse and longitudinal waves, and be able to explain qualitatively why transverse waves can exhibit polarization.	✓	
b) Students should understand the inverse-square law, so they can calculate the intensity of waves at a given distance from a source of specified power and compare the intensities at different distances from the source.	✓	
3. Standing waves Students should understand the physics of standing waves, so they can:		
a) Sketch possible standing wave modes for a stretched string that is fixed at both ends, and determine the amplitude, wavelength and frequency of such standing waves.	✓	
b) Describe possible standing sound waves in a pipe that has either open or closed ends, and determine the wavelength and frequency of such standing waves.	✓	
4. Superposition Students should understand the principle of superposition, so they can apply it to traveling waves moving in opposite directions, and describe how a standing wave may be formed by superposition.	✓	
B. Physical optics		
1. Interference and diffraction Students should understand the interference and diffraction of waves, so they can:		
a) Apply the principles of interference to coherent sources in order to:		
(1) Describe the conditions under which the waves reaching an observation point from two or more sources will all interfere constructively, or under which the waves from two sources will interfere destructively.	✓	
(2) Determine locations of interference maxima or minima for two sources or determine the frequencies or wavelengths that can lead to constructive or destructive interference at a certain point.	✓	
(3) Relate the amplitude produced by two or more sources that interfere constructively to the amplitude and intensity produced by a single source.	✓	
b) Apply the principles of interference and diffraction to waves that pass through a single or double slit or through a diffraction grating, so they can:		
(1) Sketch or identify the intensity pattern that results when monochromatic waves pass through a single slit and fall on a distant screen, and describe how this pattern will change if the slit width or the wavelength of the waves is changed.	✓	

Objectives for the AP [®] Physics Courses	AP Course	
	B	C
(2) Calculate, for a single-slit pattern, the angles or the positions on a distant screen where the intensity is zero.	✓	
(3) Sketch or identify the intensity pattern that results when monochromatic waves pass through a double slit, and identify which features of the pattern result from single-slit diffraction and which from two-slit interference.	✓	
(4) Calculate, for a two-slit interference pattern, the angles or the positions on a distant screen at which intensity maxima or minima occur.	✓	
(5) Describe or identify the interference pattern formed by a diffraction grating, calculate the location of intensity maxima, and explain qualitatively why a multiple-slit grating is better than a two-slit grating for making accurate determinations of wavelength.	✓	
c) Apply the principles of interference to light reflected by thin films, so they can:		
(1) State under what conditions a phase reversal occurs when light is reflected from the interface between two media of different indices of refraction.	✓	
(2) Determine whether rays of monochromatic light reflected perpendicularly from two such interfaces will interfere constructively or destructively, and thereby account for Newton's rings and similar phenomena, and explain how glass may be coated to minimize reflection of visible light.	✓	
2. Dispersion of light and the electromagnetic spectrum Students should understand dispersion and the electromagnetic spectrum, so they can:		
a) Relate a variation of index of refraction with frequency to a variation in refraction.	✓	
b) Know the names associated with electromagnetic radiation and be able to arrange in order of increasing wavelength the following: visible light of various colors, ultraviolet light, infrared light, radio waves, x-rays, and gamma rays.	✓	
C. Geometric optics		
1. Reflection and refraction Students should understand the principles of reflection and refraction, so they can:		
a) Determine how the speed and wavelength of light change when light passes from one medium into another.	✓	
b) Show on a diagram the directions of reflected and refracted rays.	✓	
c) Use Snell's Law to relate the directions of the incident ray and the refracted ray, and the indices of refraction of the media.	✓	
d) Identify conditions under which total internal reflection will occur.	✓	
2. Mirrors Students should understand image formation by plane or spherical mirrors, so they can:		
a) Locate by ray tracing the image of an object formed by a plane mirror, and determine whether the image is real or virtual, upright or inverted, enlarged or reduced in size.	✓	
b) Relate the focal point of a spherical mirror to its center of curvature.	✓	
c) Locate by ray tracing the image of a real object, given a diagram of a mirror with the focal point shown, and determine whether the image is real or virtual, upright or inverted, enlarged or reduced in size.	✓	
d) Use the mirror equation to relate the object distance, image distance and focal length for a lens, and determine the image size in terms of the object size.	✓	

Objectives for the AP [®] Physics Courses	AP Course	
	B	C
3. Lenses Students should understand image formation by converging or diverging lenses, so they can:		
a) Determine whether the focal length of a lens is increased or decreased as a result of a change in the curvature of its surfaces, or in the index of refraction of the material of which the lens is made, or the medium in which it is immersed.	✓	
b) Determine by ray tracing the location of the image of a real object located inside or outside the focal point of the lens, and state whether the resulting image is upright or inverted, real or virtual.	✓	
c) Use the thin lens equation to relate the object distance, image distance and focal length for a lens, and determine the image size in terms of the object size.	✓	
d) Analyze simple situations in which the image formed by one lens serves as the object for another lens.	✓	
V. ATOMIC AND NUCLEAR PHYSICS		
A. Atomic physics and quantum effects		
1. Photons, the photoelectric effect, Compton scattering, x-rays		
a) Students should know the properties of photons, so they can:		
(1) Relate the energy of a photon in joules or electron-volts to its wavelength or frequency.	✓	
(2) Relate the linear momentum of a photon to its energy or wavelength, and apply linear momentum conservation to simple processes involving the emission, absorption or reflection of photons.	✓	
(3) Calculate the number of photons per second emitted by a monochromatic source of specific wavelength and power.	✓	
b) Students should understand the photoelectric effect, so they can:		
(1) Describe a typical photoelectric-effect experiment, and explain what experimental observations provide evidence for the photon nature of light.	✓	
(2) Describe qualitatively how the number of photoelectrons and their maximum kinetic energy depend on the wavelength and intensity of the light striking the surface, and account for this dependence in terms of a photon model of light.	✓	
(3) Determine the maximum kinetic energy of photoelectrons ejected by photons of one energy or wavelength, when given the maximum kinetic energy of photoelectrons for a different photon energy or wavelength.	✓	
(4) Sketch or identify a graph of stopping potential versus frequency for a photoelectric-effect experiment, determine from such a graph the threshold frequency and work function and calculate an approximate value of h/e .	✓	
c) Students should understand Compton scattering, so they can:		
(1) Describe Compton's experiment, and state what results were observed and by what sort of analysis these results may be explained.	✓	
(2) Account qualitatively for the increase of photon wavelength that is observed, and explain the significance of the Compton wavelength.	✓	
d) Students should understand the nature and production of x-rays, so they can calculate the shortest wavelength of x-rays that may be produced by electrons accelerated through a specified voltage.	✓	

Objectives for the AP [®] Physics Courses	AP Course	
	B	C
2. Atomic energy levels Students should understand the concept of energy levels for atoms, so they can:		
a) Calculate the energy or wavelength of the photon emitted or absorbed in a transition between specified levels, or the energy or wavelength required to ionize an atom.	✓	
b) Explain qualitatively the origin of emission or absorption spectra of gases.	✓	
c) Calculate the wavelength or energy for a single-step transition between levels, given the wavelengths or energies of photons emitted or absorbed in a two-step transition between the same levels.	✓	
d) Draw a diagram to depict the energy levels of an atom when given an expression for these levels, and explain how this diagram accounts for the various lines in the atomic spectrum.	✓	
3. Wave-particle duality Students should understand the concept of de Broglie wavelength, so they can:		
a) Calculate the wavelength of a particle as a function of its momentum.	✓	
b) Describe the Davisson-Germer experiment, and explain how it provides evidence for the wave nature of electrons.	✓	
B. Nuclear Physics		
1. Nuclear reactions (including conservation of mass number and charge)		
a) Students should understand the significance of the mass number and charge of nuclei, so they can:		
(1) Interpret symbols for nuclei that indicate these quantities.	✓	
(2) Use conservation of mass number and charge to complete nuclear reactions.	✓	
(3) Determine the mass number and charge of a nucleus after it has undergone specified decay processes.	✓	
b) Students should know the nature of the nuclear force, so they can compare its strength and range with those of the electromagnetic force.	✓	
c) Students should understand nuclear fission, so they can describe a typical neutron-induced fission and explain why a chain reaction is possible.	✓	
2. Mass-energy equivalence Students should understand the relationship between mass and energy (mass-energy equivalence), so they can:		
a) Qualitatively relate the energy released in nuclear processes to the change in mass.	✓	
b) Apply the relationship $\Delta E = (\Delta m)c^2$ in analyzing nuclear processes.	✓	
LABORATORY AND EXPERIMENTAL SITUATIONS These objectives overlay the content objectives, and are assessed in the context of those objectives.		
1. Design experiments Students should understand the process of designing experiments, so they can:		
a) Describe the purpose of an experiment or a problem to be investigated.	✓	✓
b) Identify equipment needed and describe how it is to be used.	✓	✓
c) Draw a diagram or provide a description of an experimental setup.	✓	✓
d) Describe procedures to be used, including controls and measurements to be taken.	✓	✓
2. Observe and measure real phenomena Students should be able to make relevant observations, and be able to take measurements with a variety of instruments (cannot be assessed via paper-and-pencil examinations).		

Objectives for the AP [®] Physics Courses	AP Course	
	B	C
3. Analyze data Students should understand how to analyze data, so they can:		
a) Display data in graphical or tabular form.	✓	✓
b) Fit lines and curves to data points in graphs.	✓	✓
c) Perform calculations with data.	✓	✓
d) Make extrapolations and interpolations from data.	✓	✓
4. Analyze errors Students should understand measurement and experimental error, so they can:		
a) Identify sources of error and how they propagate.	✓	✓
b) Estimate magnitude and direction of errors.	✓	✓
c) Determine significant digits.	✓	✓
d) Identify ways to reduce error.	✓	✓
5. Communicate results Students should understand how to summarize and communicate results, so they can:		
a) Draw inferences and conclusions from experimental data.	✓	✓
b) Suggest ways to improve experiment.	✓	✓
c) Propose questions for further study.	✓	✓

THE EXAMS

The AP Physics B Exam is 3 hours long, divided equally between a 70-question multiple-choice section and a free-response section. The two sections are weighted equally, and a single score is reported for the B Exam.

The free-response section will usually contain 6 or 7 questions. Examples of possible formats are 2 questions of about 17 minutes each and 5 shorter questions of about 11 minutes each, or 4 questions of about 17 minutes each and 2 shorter questions of about 11 minutes each. However, future exams might include a combination of questions of other lengths.

Each Physics C Exam is 1 hour and 30 minutes long. A student may take either or both exams, and separate scores are reported for each. The time for each exam is divided equally between a 35-question multiple-choice section and a free-response section; the two sections are weighted equally in the determination of each score. The usual format for each free-response section has been 3 questions, each taking about 15 minutes. However, future exams might include a larger number of shorter questions.

The percentages of each exam devoted to each major category are specified in the preceding pages. Departures from these percentages in the free-response section in any given year are compensated for in the multiple-choice section so that the overall topic distribution for the entire exam is achieved as closely as possible, although it may not be reached exactly.

Some questions, particularly in the free-response sections, may involve topics from two or more major categories. For example, a question may utilize a setting involving principles from electricity and magnetism or atomic and nuclear physics, but parts of the question may also involve the application of principles of mechanics to this setting, either alone or in combination with the principles from electricity and magnetism or atomic and nuclear physics. Such a question would not be classified uniquely according to any particular topic but would receive partial classifications by topics in proportion to the principles needed to arrive at the answers.

On both exams the multiple-choice section emphasizes the breadth of the students' knowledge and understanding of the basic principles of physics; the free-response section emphasizes the application of these principles in greater depth in solving more extended problems. In general, questions may ask students to:

- determine directions of vectors or paths of particles;
- draw or interpret diagrams;
- interpret or express physical relationships in graphical form;
- account for observed phenomena;
- interpret experimental data, including their limitations and uncertainties;
- construct and use conceptual models and explain their limitations;
- explain steps taken to arrive at a result or to predict future physical behavior;
- manipulate equations that describe physical relationships;
- obtain reasonable estimates; or

- solve problems that require the determination of physical quantities in either numerical or symbolic form and that may require the application of single or multiple physical concepts.

Laboratory-related questions may ask students to:

- design experiments, including identifying equipment needed and describing how it is to be used, drawing diagrams or providing descriptions of experimental setups, or describing procedures to be used, including controls and measurements to be taken;
- analyze data, including displaying data in graphical or tabular form, fitting lines and curves to data points in graphs, performing calculations with data or making extrapolations and interpolations from data;
- analyze errors, including identifying sources of errors and how they propagate, estimating magnitude and direction of errors, determining significant digits or identifying ways to reduce errors; or
- communicate results, including drawing inferences and conclusions from experimental data, suggesting ways to improve experiments or proposing questions for further study.

The free-response section of each exam is printed in a separate booklet in which each part of a question is followed by a blank space for the student's solution. The same questions without the blank answer spaces are printed on green paper as an insert in the exam booklet. This green insert also contains a Table of Information and tables of commonly used equations. The Table of Information, which is also printed near the front of each multiple-choice section, includes numerical values of some physical constants and conversion factors and states some conventions used in the exams. The equation tables are described in greater detail in a later section. The green insert can be removed from the free-response answer booklet and used for reference when answering the free-response questions only.

The International System of Units (SI) is used predominantly in both exams. The use of rulers or straightedges is permitted on the free-response sections to facilitate the sketching of graphs or diagrams that might be required in these sections.

Since the complete exams are intended to provide the maximum information about differences in students' achievement in physics, students may find them more difficult than many classroom exams. The best way for teachers to familiarize their students with the level of difficulty is to give them actual released exams (both multiple-choice and free-response sections) from past administrations. Information about ordering publications is on page 81. Recent free-response sections can also be found on AP Central, along with scoring guidelines and some sample student responses.

The Free-Response Sections — Student Presentation

Students are expected to show their work in the spaces provided for the solution for each part of a free-response question. If they need more space, they should clearly indicate where the work is continued or they may lose credit for it. If students make a mistake, they may cross it out or erase it. Crossed-out work and any work shown on

the green insert will not be scored, and credit may be lost for incorrect work that is not crossed out.

In scoring the free-response sections, credit for the answers depends on the quality of the solutions and the explanations given; partial solutions may receive partial credit, so students are advised to show all their work. Correct answers without supporting work may lose credit. This is especially true when students are asked specifically to justify their answers, in which case the Exam Readers are looking for some verbal or mathematical analysis that shows how the students arrived at their answers. Also, all final numerical answers should include appropriate units.

On the AP Physics Exams the words “justify,” “explain,” “calculate,” “what is,” “determine,” “derive,” “sketch” and “plot” have precise meanings.

Students should pay careful attention to these words in order to obtain maximum credit and should avoid including irrelevant or extraneous material in their answers.

The ability to justify an answer in words shows understanding of the principles underlying physical phenomena in addition to the ability to perform the mathematical manipulations necessary to generate a correct answer. Students will be directed to justify or explain their answers on many of the questions they encounter on the AP Physics Exams. The words “justify” and “explain” indicate that the student should support the answer with prose, equations, calculations, diagrams or graphs. The prose or equations may in some cases refer to fundamental ideas or relations in physics, such as Newton’s laws, conservation of energy, Gauss’s law or Bernoulli’s equation. In other cases, the justification or explanation may take the form of analyzing the behavior of an equation for large or small values of a variable in the equation.

The words “calculate,” “what is,” “determine” and “derive” have distinct meanings on the AP Physics Exams. “Calculate” means that a student is expected to show work leading to a final answer, which may be algebraic but more often is numerical. “What is” and “determine” indicate that work need not necessarily be explicitly shown to obtain full credit. Showing work leading to answers is a good idea, as it may earn a student partial credit in the case of an incorrect answer, but this step may be skipped by the confident or harried student. “Derive” is more specific and indicates that the students need to begin their solutions with one or more fundamental equations, such as those given on the AP Physics Exam equation sheet. The final answer, usually algebraic, is then obtained through the appropriate use of mathematics.

The words “sketch” and “plot” relate to student-produced graphs. “Sketch” means to draw a graph that illustrates key trends in a particular relationship, such as slope, curvature, intercept(s), or asymptote(s). Numerical scaling or specific data points are not required in a sketch. “Plot” means to draw the data points given in the problem on the grid provided, either using the given scale or indicating the scale and units when none are provided.

Exam questions that require the drawing of free-body or force diagrams will direct the students to “draw and label the forces (not components) that act on the [object]”, where [object] is replaced by a reference specific to the question, such as “the car when it reaches the top of the hill.” Any components that are included in the diagram will be scored in the same way as incorrect or extraneous forces. In addition, in any subsequent part asking for a solution that would typically make use of the diagram, the following will be included: “If you need to draw anything other than what you have

shown in part [x] to assist in your solution, use the space below. Do NOT add anything to the figure in part [x].” This will give students the opportunity to construct a working diagram showing any components that are appropriate to the solution of the problem. This second diagram will not be scored.

Strict rules regarding significant digits are usually not applied to the scoring of numerical answers. However, in some cases answers containing too many digits may be penalized. In general, two to four significant digits are acceptable. Exceptions to these guidelines usually occur when rounding makes a difference in obtaining a reasonable answer. For example, suppose a solution requires subtracting two numbers that should have five significant digits and that differ starting with the fourth digit (e.g., 20.295 and 20.278). Rounding to three digits will lose the accuracy required to determine the difference in the numbers, and some credit may be lost.

Simplification of algebraic and numerical answers is encouraged, though it should always be balanced with students’ efficient use of exam time. Simplifying an answer will often reveal a characteristic of the underlying physics that may be useful in a subsequent part of the exam question. A simplified answer is the clearest way to communicate with the professors and AP teachers who score the exams. Equivalent answers are entitled to full credit, and the Exam Readers always evaluate unsimplified answers for correctness. Yet, however careful the Readers are, there is always the chance for error in their evaluations, and thus simplification may be in the students’ best interest.

Additional information about study skills and test-taking strategies can be found at AP Central.

Calculators and Equation Tables

Policies regarding the use of calculators on the exams take into account the expansion of the capabilities of scientific calculators, which now include not only programming and graphing functions but also the availability of stored equations and other data. For taking the sections of the exams in which calculators are permitted, students should be allowed to use the calculators to which they are accustomed, except as noted below.* On the other hand, they should not have access to information in their calculators that is not available to other students, if that information is needed to answer the questions.

Calculators are NOT permitted on the multiple-choice sections of the Physics B and Physics C exams. The purpose of the multiple-choice sections is to assess the breadth of students’ knowledge and understanding of the basic concepts of physics. The multiple-choice questions emphasize conceptual understanding and qualitative applications. However, many physical definitions and principles are quantitative by nature and can therefore be expressed as equations. The knowledge of these basic definitions and principles, expressed as equations, is a part of the content of physics that should be learned by physics students and will continue to be assessed in

***Exceptions to calculator use.** Calculators that are not permitted are PowerBooks and portable/handheld computers; electronic writing pads or pen-input/stylus-driven devices (e.g., Palm, PDAs, Casio ClassPad 300); pocket organizers; models with QWERTY (i.e., typewriter) keypads (e.g., TI-92 Plus, Voyage 200); models with paper tapes; models that make noise or “talk”; models that require an electrical outlet; cell phone calculators. Students may not share calculators.

the multiple-choice sections. However, any numeric calculations using these equations required in the multiple-choice sections will be kept simple. Also, in some questions, the answer choices differ by several orders of magnitude so that the questions can be answered by estimation. Students should be encouraged to develop their skills not only in estimating answers but also in recognizing answers that are physically unreasonable or unlikely.

Calculators are allowed on the free-response section of all exams. Any programmable or graphing calculator may be used except as noted on the previous page,* and students will not be required to erase their calculator memories before and after the exam. The free-response sections emphasize solving in-depth problems where knowledge of which principles to apply and how to apply them is the most important aspect of the solution to these problems.

Regardless of the type of calculator allowed, the exams are designed and scored to minimize the necessity of doing lengthy computations. When free-response problems involve calculations, most of the points awarded in the scoring of the solution are given for setting up the solution correctly rather than for actually carrying out the computation.

Tables containing commonly used physics equations are printed in the green insert provided with each exam for students to use when taking the free-response section. The equation tables may NOT be used when taking the multiple-choice section. The Table of Information and the equation tables developed for the 2012 exams are included as an insert in this book so that they can easily be removed and duplicated for use by students. This version of the tables will remain in effect until revisions are needed. When new tables are required, they will be printed and distributed with the Course Description at least a year in advance so that students can become accustomed to using them throughout the year. However, since the equations will be provided with the exams, students are NOT allowed to bring their own copies to the exam room.

One of the purposes of providing the commonly used equations is to make the free-response sections equitable for those students who do not have access to equations stored in their calculators. The availability of these equations means that in the scoring of the free-response sections little or no credit will be awarded for simply writing down correct equations or for ambiguous answers unsupported by explanations or logical development.

The equations in the tables express relationships that are encountered most frequently in AP Physics courses and exams. However, they do not include all equations that might possibly be used. For example, they do not include many equations that can be derived by combining others in the tables. Nor do they include equations that are simply special cases of any that are in the tables. Students are responsible for understanding the physical principles that underlie each equation and for knowing the conditions for which each equation is applicable.

The equations are grouped in tables according to major content category. Within each table, the symbols used for the variables in that table are defined. However, in some cases the same symbol is used to represent different quantities in different tables. It should be noted that there is no uniform convention among textbooks for the symbols used in writing equations. The equation tables follow many common conventions, but in some cases consistency was sacrificed for the sake of clarity.

In summary, the purpose of minimizing numerical calculations in both sections of the exams and providing equations with the free-response sections is to place greater emphasis on the understanding and application of fundamental physical principles and concepts. For solving problems, a sophisticated programmable or graphing calculator, or the availability of stored equations, is no substitute for a thorough grasp of the physics involved.

Physics B Sample Multiple-Choice Questions

Most of the following sample questions, illustrative of the Physics B Exam, have appeared in past exams. The answers are on page 52. Additional questions can be found in the *2009 AP Physics B and Physics C Released Exams* book.

Note: Units associated with numerical quantities are abbreviated, using the abbreviations listed in the table of information included with the exams (see insert in this book.) To simplify calculations, you may use $g = 10 \text{ m/s}^2$ in all problems.

Directions: Each of the questions or incomplete statements below is followed by five suggested answers or completions. Select the one that is best in each case.

- An object is thrown with a horizontal velocity of 20 m/s from a cliff that is 125 m above level ground. If air resistance is negligible, the time that it takes the object to fall to the ground from the cliff is most nearly
 - 3 s
 - 5 s
 - 6 s
 - 12 s
 - 25 s

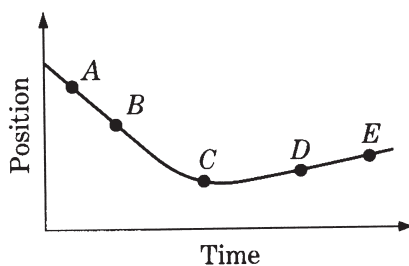

- The motion of a particle along a straight line is represented by the position versus time graph above. At which of the labeled points on the graph is the magnitude of the acceleration of the particle greatest?
 - A
 - B
 - C
 - D
 - E

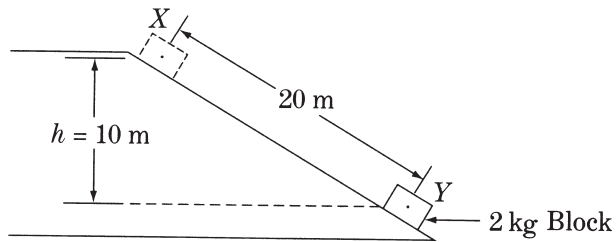
Questions 3–4

A 2 kg block, starting from rest, slides 20 m down a frictionless inclined plane from X to Y , dropping a vertical distance of 10 m as shown above.

3. The magnitude of the net force on the block while it is sliding is most nearly
 - (A) 0.1 N
 - (B) 0.4 N
 - (C) 2.5 N
 - (D) 5.0 N
 - (E) 10.0 N

4. The speed of the block at point Y is most nearly
 - (A) 7 m/s
 - (B) 10 m/s
 - (C) 14 m/s
 - (D) 20 m/s
 - (E) 100 m/s

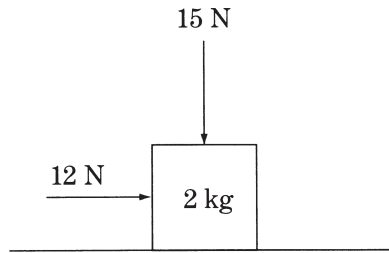

5. A block of mass 2 kg slides along a horizontal tabletop. A horizontal applied force of 12 N and a vertical applied force of 15 N act on the block, as shown above. If the coefficient of kinetic friction between the block and the table is 0.2, the frictional force exerted on the block is most nearly
- (A) 1 N
 - (B) 3 N
 - (C) 4 N
 - (D) 5 N
 - (E) 7 N

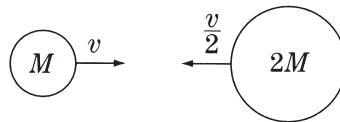

6. A ball of mass M and speed v collides head-on with a ball of mass $2M$ and speed $\frac{v}{2}$, as shown above. If the two balls stick together, their speed after the collision is
- (A) 0
 - (B) $\frac{v}{2}$
 - (C) $\frac{\sqrt{2}v}{2}$
 - (D) $\frac{\sqrt{3}v}{2}$
 - (E) $\frac{3v}{2}$

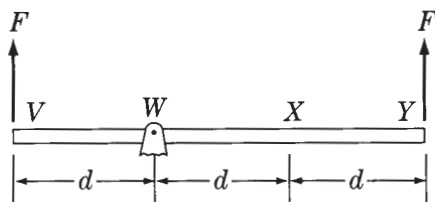

7. A massless rigid rod of length $3d$ is pivoted at a fixed point W , and two forces each of magnitude F are applied vertically upward as shown above. A third vertical force of magnitude F may be applied, either upward or downward, at one of the labeled points. With the proper choice of direction at each point, the rod can be in equilibrium if the third force of magnitude F is applied at point
- W only
 - Y only
 - V or X only
 - V or Y only
 - V , W , or X
8. An ideal monatomic gas is compressed while its temperature is held constant. What happens to the internal energy of the gas during this process, and why?
- It decreases because the gas does work on its surroundings.
 - It decreases because the molecules of an ideal gas collide.
 - It does not change because the internal energy of an ideal gas depends only on its temperature.
 - It increases because work is done on the gas.
 - It increases because the molecules travel a shorter path between collisions.

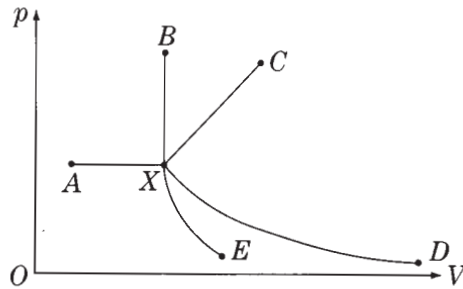

9. In the pV diagram above, the initial state of a gas is shown at point X . Which of the curves represents a process in which no work is done on or by the gas?
- (A) XA
 - (B) XB
 - (C) XC
 - (D) XD
 - (E) XE



10. An isolated positive charge q is in the plane of the page, as shown above. The directions of the electric field vectors at points P and T , which are also in the plane of the page, are given by which of the following?
- | <u>Point P</u> | <u>Point T</u> |
|-----------------------------|-------------------------------|
| (A) Left | Right |
| (B) Right | Left |
| (C) Left | Toward the top of the page |
| (D) Right | Toward the top of the page |
| (E) Left | Toward the bottom of the page |

Questions 11–12 relate to the following circuit in which the battery has zero internal resistance.

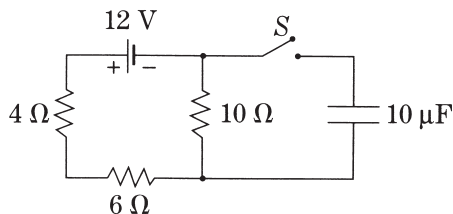

11. What is the current in the $4\ \Omega$ resistor while the switch S is open?
- (A) 0 A
 (B) 0.6 A
 (C) 1.2 A
 (D) 2.0 A
 (E) 3.0 A
12. When the switch S is closed and the $10\ \mu\text{F}$ capacitor is fully charged, what is the voltage across the capacitor?
- (A) 0 V
 (B) 6 V
 (C) 12 V
 (D) 60 V
 (E) 120 V

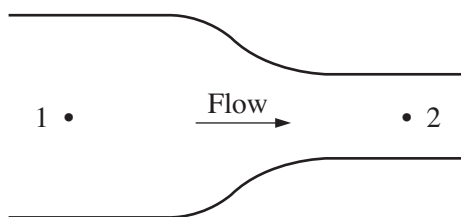

13. A fluid flows steadily from left to right in the pipe shown above. The diameter of the pipe is less at point 2 than at point 1, and the fluid density is constant throughout the pipe. How do the velocity of flow and the pressure at points 1 and 2 compare?

	<u>Velocity</u>	<u>Pressure</u>
(A)	$v_1 < v_2$	$p_1 = p_2$
(B)	$v_1 < v_2$	$p_1 > p_2$
(C)	$v_1 = v_2$	$p_1 < p_2$
(D)	$v_1 > v_2$	$p_1 = p_2$
(E)	$v_1 > v_2$	$p_1 > p_2$

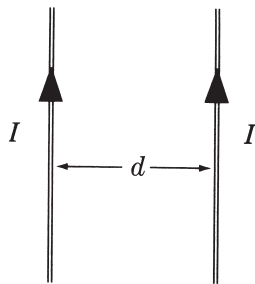

14. Two long parallel wires, separated by a distance d , carry equal currents I toward the top of the page, as shown above. The magnetic field due to the wires at a point halfway between them is
- (A) zero in magnitude
 - (B) directed into the page
 - (C) directed out of the page
 - (D) directed to the right
 - (E) directed to the left

15. A source S of sound and a listener L each can be at rest or can move directly toward or away from each other with speed v_0 . In which of the following situations will the observer hear the lowest frequency of sound from the source?

- (A) S and L are at rest ($v=0$).
- (B) S is at rest ($v=0$) and L moves to the right ($v=v_0$).
- (C) S moves to the left ($v=v_0$) and L is at rest ($v=0$).
- (D) S moves to the left ($v=v_0$) and L moves to the right ($v=v_0$).
- (E) S moves to the right ($v=v_0$) and L moves to the left ($v=v_0$).

16. The wavelength of yellow sodium light in vacuum is 5.89×10^{-7} m. The speed of this light in glass with an index of refraction of 1.5 is most nearly
- (A) 4×10^{-7} m/s
 - (B) 9×10^{-7} m/s
 - (C) 2×10^8 m/s
 - (D) 3×10^8 m/s
 - (E) 4×10^8 m/s

17. An object O is in front of a convex mirror. The focal point of the mirror is labeled F and the center of curvature is labeled C . The direction of the reflected ray is correctly illustrated in all of the following EXCEPT which diagram?

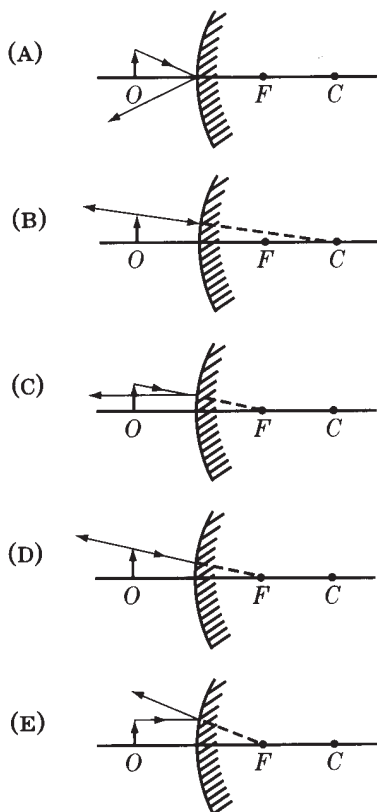

18. A system initially consists of an electron and an incident photon. The electron and the photon collide, and afterward the system consists of the electron and a scattered photon. The electron gains kinetic energy as a result of this collision. Compared with the incident photon, the scattered photon has
- (A) the same energy
 - (B) a smaller speed
 - (C) a larger speed
 - (D) a smaller frequency
 - (E) a larger frequency

19. In an experiment, light of a particular wavelength is incident on a metal surface, and electrons are emitted from the surface as a result. To produce more electrons per unit time but with less kinetic energy per electron, the experimenter should do which of the following?
- (A) Increase the intensity and decrease the wavelength of the light.
 - (B) Increase the intensity and the wavelength of the light.
 - (C) Decrease the intensity and the wavelength of the light.
 - (D) Decrease the intensity and increase the wavelength of the light.
 - (E) None of the above would produce the desired result.
20. When ^{10}B is bombarded by neutrons, a neutron can be absorbed and an alpha particle (^4He) emitted. The kinetic energy of the reaction products is equal to the
- (A) kinetic energy of the incident neutron
 - (B) total energy of the incident neutron
 - (C) energy equivalent of the mass decrease in the reaction
 - (D) energy equivalent of the mass decrease in the reaction, minus the kinetic energy of the incident neutron
 - (E) energy equivalent of the mass decrease in the reaction, plus the kinetic energy of the incident neutron

Answers to Physics B Multiple-Choice Questions

1 – B	5 – E	9 – B	13 – B	17 – D
2 – C	6 – A	10 – E	14 – A	18 – D
3 – E	7 – C	11 – B	15 – D	19 – B
4 – C	8 – C	12 – B	16 – C	20 – E

Physics B Sample Free-Response Questions**PHYSICS B****SECTION II****Time—90 minutes****7 Questions**

Directions: Answer all seven questions, which are weighted according to the points indicated. The suggested times are about 17 minutes for answering each of Questions 1-2 and about 11 minutes for answering each of Questions 3-7. The parts within a question may not have equal weight. Show all your work in the pink booklet in the spaces provided after each part, NOT in this green insert.

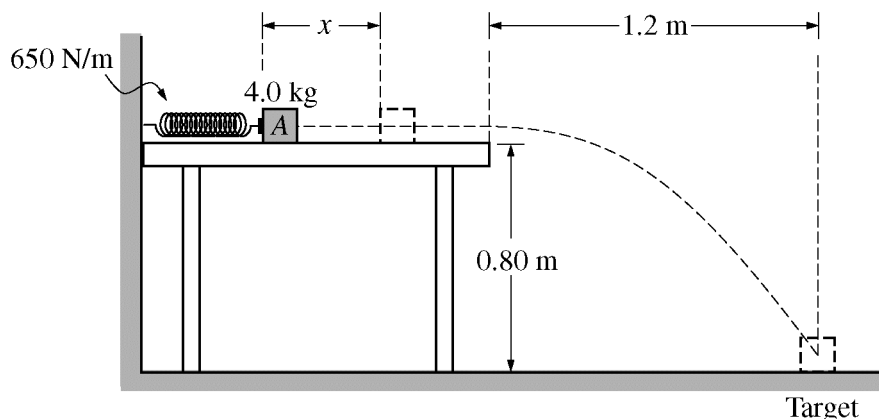

Note: Figure not drawn to scale.

1. (15 points)

Block *A* of mass 4.0 kg is on a horizontal, frictionless tabletop and is placed against a spring of negligible mass and spring constant 650 N/m. The other end of the spring is attached to a wall. The block is pushed toward the wall until the spring has been compressed a distance x , as shown above. The block is released and follows the trajectory shown, falling 0.80 m vertically and striking a target on the floor that is a horizontal distance of 1.2 m from the edge of the table. Air resistance is negligible.

- Calculate the time elapsed from the instant block *A* leaves the table to the instant it strikes the floor.
- Calculate the speed of the block as it leaves the table.
- Calculate the distance x the spring was compressed.

Block *B*, also of mass 4.0 kg, is now placed at the edge of the table. The spring is again compressed a distance x , and block *A* is released. As it nears the end of the table, it instantaneously collides with and sticks to block *B*. The blocks follow the trajectory shown in the figure below and strike the floor at a horizontal distance d from the edge of the table.

Sample Questions for **Physics B**

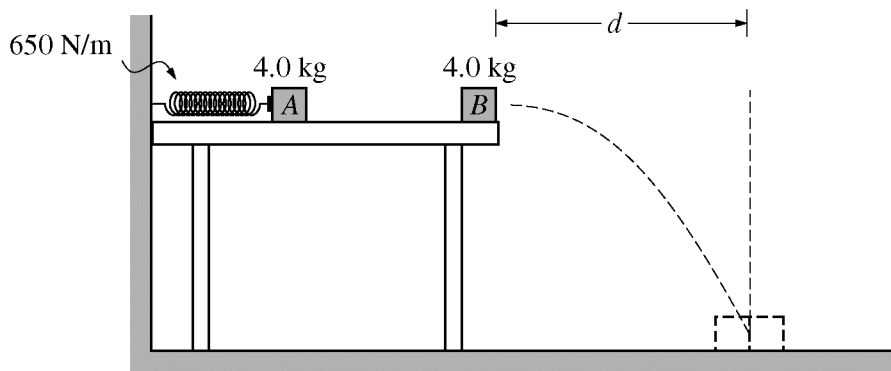

Note: Figure not drawn to scale.

- (d) Calculate d if x is equal to the value determined in part (c).
- (e) Consider the system consisting of the spring, the blocks, and the table. How does the total mechanical energy E_2 of the system just before the blocks leave the table compare to the total mechanical energy E_1 of the system just before block A is released?

$E_2 < E_1$
 $E_2 = E_1$
 $E_2 > E_1$

Justify your answer.

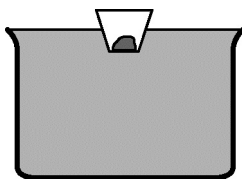

2. (15 points)

A large pan is filled to the top with oil of density ρ_O . A plastic cup of mass m_C , containing a sample of known mass m_S , is placed in the oil so that the cup and sample float, as shown above. The oil that overflows from the pan is collected, and its volume is measured. The procedure is repeated with a variety of samples of different mass, and the pan is refilled each time.

- (a) On the dot below that represents the cup-sample system, draw and label the forces (not components) that act on the system when it is floating on the surface of the oil.



- (b) Derive an expression for the overflow volume V_O (the volume of oil that overflows due to the floating system) in terms of ρ_O , m_S , m_C , and fundamental constants. If you need to draw anything other than what you have shown in part (a) to assist in your solution, use the space below. Do NOT add anything to the figure in part (a).

Assume that the following data are obtained for the overflow volume V_O for several sample masses m_S .

Sample mass m_S (kg)	0.020	0.030	0.040	0.050	0.060	0.070
Overflow volume V_O (m^3)	29×10^{-6}	38×10^{-6}	54×10^{-6}	62×10^{-6}	76×10^{-6}	84×10^{-6}

- (c) Graph the data on the axes below, plotting the overflow volume as a function of sample mass. Place numbers and units on both axes. Draw a straight line that best represents the data.

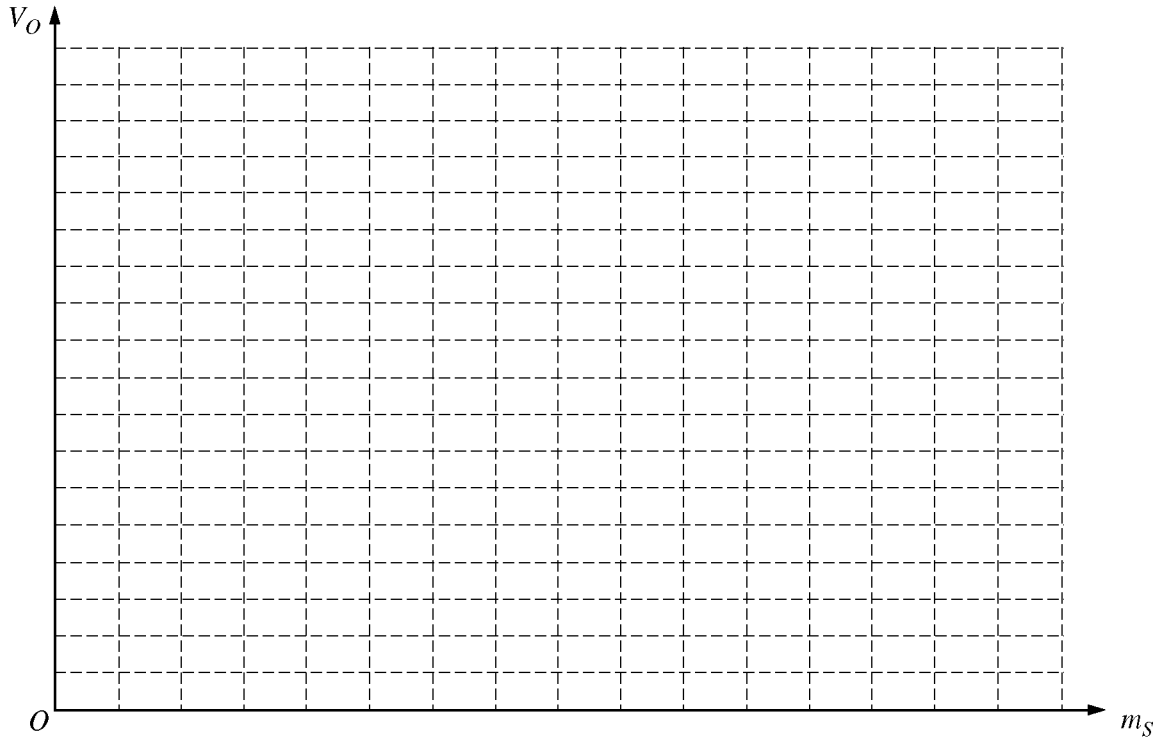

- (d) Use the slope of the best-fit line to calculate the density of the oil.
(e) What is the physical significance of the intercept of your line with the vertical axis?

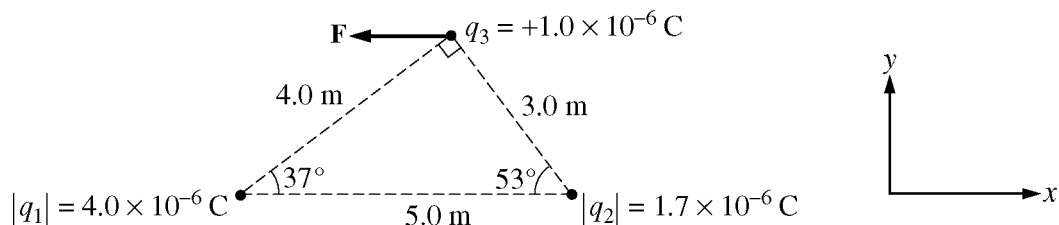

3. (10 points)

Three particles are fixed in place in a horizontal plane, as shown in the figure above. Particle 3 at the top of the triangle has charge q_3 of $+1.0 \times 10^{-6} \text{ C}$, and the electrostatic force \mathbf{F} on it due to the charge on the two other particles is measured to be entirely in the negative x -direction. The magnitude of the charge q_1 on particle 1 is known to be $4.0 \times 10^{-6} \text{ C}$, and the magnitude of the charge q_2 on particle 2 is known to be $1.7 \times 10^{-6} \text{ C}$, but their signs are not known.

(a) Determine the signs of the charges q_1 and q_2 and indicate the correct signs below.

q_1 Negative q_2 Negative
 Positive Positive

(b) On the diagram below, draw and label arrows to indicate the direction of the force F_1 exerted by particle 1 on particle 3 and the force F_2 exerted by particle 2 on particle 3.

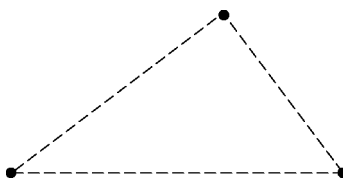

- (c) Calculate the magnitude of \mathbf{F} , the electrostatic force on particle 3.
- (d) Calculate the magnitude of the electric field at the position of particle 3 due to the other two particles.
- (e) On the figure below, draw a small \times in the box that is at a position where another positively charged particle could be fixed in place so that the electrostatic force on particle 3 is zero.

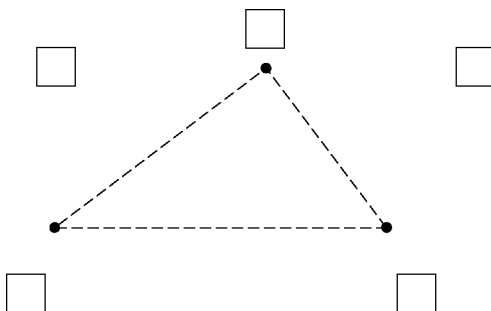

Justify your answer.

4. (10 points)

A locomotive runs on a steam engine with a power output of 4.5×10^6 W and an efficiency of 12 percent.

- (a) Calculate the rate at which heat is being delivered to the steam engine.
- (b) Calculate the magnitude of the resistive forces acting on the locomotive when it is moving with a constant speed of 7.0 m/s.

Suppose the gas in another heat engine follows the simplified path *ABCD*A in the *PV* diagram below at a rate of 4 cycles per second.

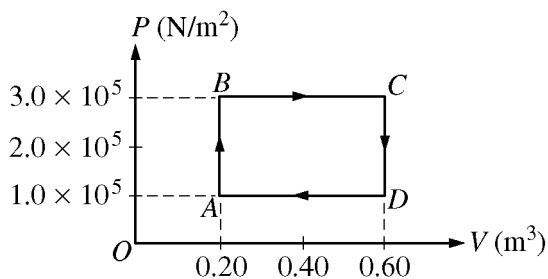

- (c)
 - i. What does the area bounded by path *ABCD*A represent?
 - ii. Calculate the power output of the engine.
- (d) Indicate below all of the processes during which heat is added to the gas in the heat engine.

___ *AB* ___ *BC* ___ *CD* ___ *DA*

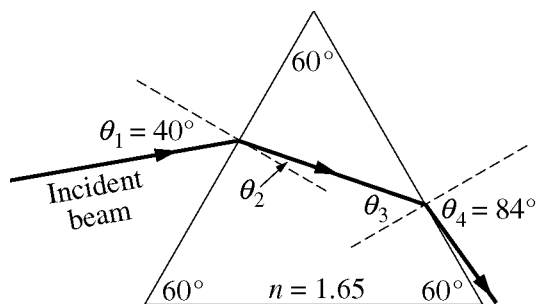

Note: Figure not drawn to scale.

5. (10 points)

As shown above, a beam of red light of wavelength 6.65×10^{-7} m in air is incident on a glass prism at an angle θ_1 with the normal. The glass has index of refraction $n = 1.65$ for the red light. When $\theta_1 = 40^\circ$, the beam emerges on the other side of the prism at an angle $\theta_4 = 84^\circ$.

- Calculate the angle of refraction θ_2 at the left side of the prism.
- Using the same prism, describe a change to the setup that would result in total internal reflection of the beam at the right side of the prism. Justify your answer.
- The incident beam is now perpendicular to the surface. The glass is coated with a thin film that has an index of refraction $n_f = 1.38$ to reduce the partial reflection of the beam at this angle.
 - Calculate the wavelength of the red light in the film.
 - Calculate the minimum thickness of the film for which the intensity of the reflected red ray is near zero.

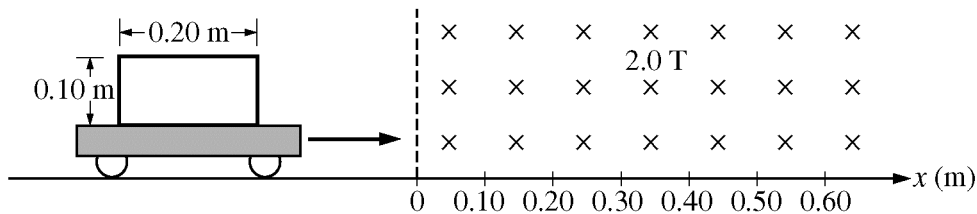

6. (10 points)

The plastic cart shown in the figure above has mass 2.5 kg and moves with negligible friction on a horizontal surface. Attached to the cart is a rigid rectangular loop of wire that is 0.10 m by 0.20 m, has resistance 4.0Ω , and has a mass that is negligible compared to the mass of the cart. The plane of the rectangular loop is parallel to the plane of the page. A uniform magnetic field of 2.0 T, perpendicular to and directed into the plane of the page, starts at $x = 0$, as shown above.

- (a) On the figure below, indicate the direction of the induced current in the loop when its front edge is at $x = 0.12$ m.

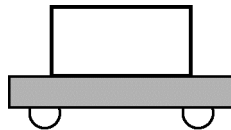

Justify your answer.

- (b) When the front edge of the rectangular loop is at $x = 0.12$ m, its speed is 3.0 m/s. Calculate the following for that instant.
- The magnitude of the induced current in the rectangular loop of wire
 - The magnitude of the net force on the loop
- (c) At a later time, the cart and loop are completely inside the magnetic field. Determine the magnitude of the net force on the loop at that time. Justify your answer.

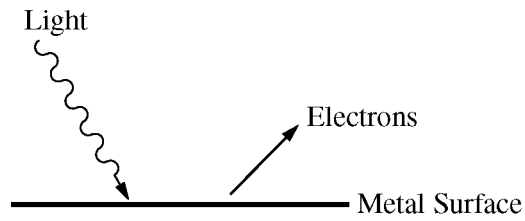

7. (10 points)

Light of wavelength 400 nm is incident on a metal surface, as shown above. Electrons are ejected from the metal surface with a maximum kinetic energy of 1.1×10^{-19} J.

- Calculate the frequency of the incoming light.
- Calculate the work function of the metal surface.
- Calculate the stopping potential for the emitted electrons.
- Calculate the momentum of an electron with the maximum kinetic energy.

Physics C: Mechanics Sample Multiple-Choice Questions

Most of the following sample questions have appeared in past exams. The answers are on page 66. Additional questions can be found in the 2009 *AP Physics B and Physics C Released Exams* book.

Note: Units associated with numerical quantities are abbreviated, using the abbreviations listed in the table of information included with the exams (see insert in this book). To simplify calculations, you may use $g = 10 \text{ m/s}^2$ in all problems.

Directions: Each of the questions or incomplete statements below is followed by five suggested answers or completions. Select the one that is best in each case.

Questions 1–2

The speed v of an automobile moving on a straight road is given in meters per second as a function of time t in seconds by the following equation:

$$v = 4 + 2t^3$$

1. What is the acceleration of the automobile at $t = 2 \text{ s}$?
 - (A) 12 m/s^2
 - (B) 16 m/s^2
 - (C) 20 m/s^2
 - (D) 24 m/s^2
 - (E) 28 m/s^2
2. How far has the automobile traveled in the interval between $t = 0$ and $t = 2 \text{ s}$?
 - (A) 16 m
 - (B) 20 m
 - (C) 24 m
 - (D) 32 m
 - (E) 72 m

3. If a particle moves in a plane so that its position is described by the functions $x = A \cos \omega t$ and $y = A \sin \omega t$, the particle is
- (A) moving with constant speed along a circle
 - (B) moving with varying speed along a circle
 - (C) moving with constant acceleration along a straight line
 - (D) moving along a parabola
 - (E) oscillating back and forth along a straight line

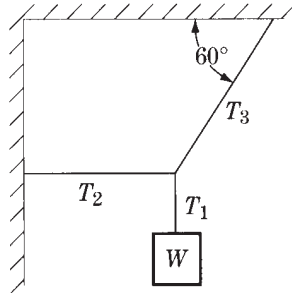

4. A system in equilibrium consists of an object of weight W that hangs from three ropes, as shown above. The tensions in the ropes are T_1 , T_2 , and T_3 . Which of the following are correct values of T_2 and T_3 ?

- | $\frac{T_2}{T_3}$ | $\frac{T_3}{T_2}$ |
|-------------------------------|---------------------------|
| (A) $W \tan 60^\circ$ | $\frac{W}{\cos 60^\circ}$ |
| (B) $W \tan 60^\circ$ | $\frac{W}{\sin 60^\circ}$ |
| (C) $W \tan 60^\circ$ | $W \sin 60^\circ$ |
| (D) $\frac{W}{\tan 60^\circ}$ | $\frac{W}{\cos 60^\circ}$ |
| (E) $\frac{W}{\tan 60^\circ}$ | $\frac{W}{\sin 60^\circ}$ |

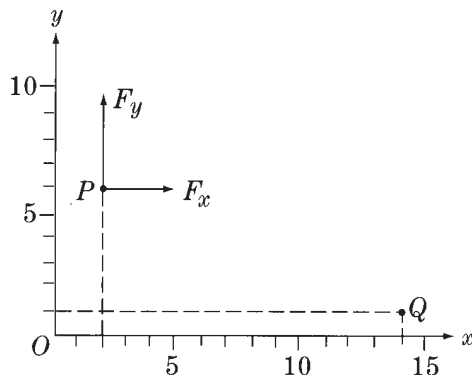

5. The constant force \mathbf{F} with components $F_x = 3 \text{ N}$ and $F_y = 4 \text{ N}$, shown above, acts on a body while that body moves from the point P ($x = 2 \text{ m}$, $y = 6 \text{ m}$) to the point Q ($x = 14 \text{ m}$, $y = 1 \text{ m}$). How much work does the force do on the body during this process?
- (A) 16 J
 (B) 30 J
 (C) 46 J
 (D) 56 J
 (E) 65 J
6. The sum of all the external forces on a system of particles is zero. Which of the following must be true of the system?
- (A) The total mechanical energy is constant.
 (B) The total potential energy is constant.
 (C) The total kinetic energy is constant.
 (D) The total linear momentum is constant.
 (E) It is in static equilibrium.



7. A toy cannon is fixed to a small cart and both move to the right with speed v along a straight track, as shown above. The cannon points in the direction of motion. When the cannon fires a projectile the cart and cannon are brought to rest. If M is the mass of the cart and cannon combined without the projectile, and m is the mass of the projectile, what is the speed of the projectile relative to the ground immediately after it is fired?

- (A) $\frac{Mv}{m}$
 (B) $\frac{(M + m)v}{m}$
 (C) $\frac{(M - m)v}{m}$
 (D) $\frac{mv}{M}$
 (E) $\frac{mv}{(M - m)}$

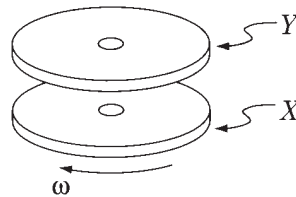

8. A disk X rotates freely with angular velocity ω on frictionless bearings, as shown above. A second identical disk Y , initially not rotating, is placed on X so that both disks rotate together without slipping. When the disks are rotating together, which of the following is half what it was before?
- (A) Moment of inertia of X
 (B) Moment of inertia of Y
 (C) Angular velocity of X
 (D) Angular velocity of Y
 (E) Angular momentum of both disks

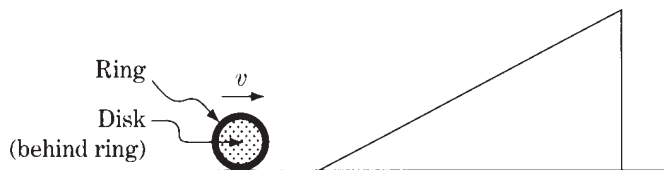

9. The ring and the disk shown above have identical masses, radii, and velocities, and are not attached to each other. If the ring and the disk each roll without slipping up an inclined plane, how will the distances that they move up the plane before coming to rest compare?
- (A) The ring will move farther than will the disk.
 (B) The disk will move farther than will the ring.
 (C) The ring and the disk will move equal distances.
 (D) The relative distances depend on the angle of elevation of the plane.
 (E) The relative distances depend on the length of the plane.
10. Let g be the acceleration due to gravity at the surface of a planet of radius R . Which of the following is a dimensionally correct formula for the minimum kinetic energy K that a projectile of mass m must have at the planet's surface if the projectile is to escape from the planet's gravitational field?
- (A) $K = \sqrt{gR}$
 (B) $K = mgR$
 (C) $K = \frac{mg}{R}$
 (D) $K = m\sqrt{\frac{g}{R}}$
 (E) $K = gR$

Answers to Physics C: Mechanics Multiple-Choice Questions

1 - D	3 - A	5 - A	7 - B	9 - A
2 - A	4 - E	6 - D	8 - C	10 - B

Physics C: Mechanics Sample Free-Response Questions

PHYSICS C: MECHANICS

SECTION II

Time—45 minutes

3 Questions

Directions: Answer all three questions. The suggested time is about 15 minutes for answering each of the questions, which are worth 15 points each. The parts within a question may not have equal weight. Show all your work in the pink booklet in the spaces provided after each part, NOT in this green insert.



Mech. 1.

Students are to conduct an experiment to investigate the relationship between the terminal speed of a stack of falling paper coffee filters and its mass. Their procedure involves stacking a number of coffee filters, like the one shown in the figure above, and dropping the stack from rest. The students change the number of filters in the stack to vary the mass m while keeping the shape of the stack the same. As a stack of coffee filters falls, there is an air resistance (drag) force acting on the filters.

- (a) The students suspect that the drag force F_D is proportional to the square of the speed v : $F_D = Cv^2$, where C is a constant. Using this relationship, derive an expression relating the terminal speed v_T to the mass m .

The students conduct the experiment and obtain the following data.

Mass of the stack of filters, m (kg)	1.12×10^{-3}	2.04×10^{-3}	2.96×10^{-3}	4.18×10^{-3}	5.10×10^{-3}
Terminal speed, v_T (m/s)	0.51	0.62	0.82	0.92	1.06

(b)

- (i) Assuming the functional relationship for the drag force above, use the grid below to plot a linear graph as a function of m to verify the relationship. Use the empty boxes in the data table, as appropriate, to record any calculated values you are graphing. Label the vertical axis as appropriate, and place numbers on both axes.

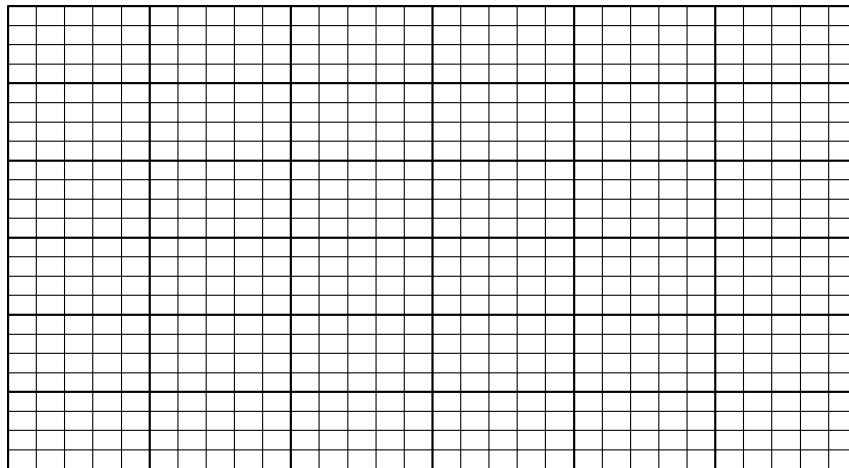

m (kg)

- (ii) Use your graph to calculate C .

A particular stack of filters with mass m is dropped from rest and reaches a speed very close to terminal speed by the time it has fallen a vertical distance Y .

(c)

- (i) Sketch an approximate graph of speed versus time from the time the filters are released up to the time $t = T$ that the filters have fallen the distance Y . Indicate time $t = T$ and terminal speed $v = v_T$ on the graph.



- (ii) Suppose you had a graph like the one sketched in (c)(i) that had a numerical scale on each axis. Describe how you could use the graph to approximate the distance Y .
- (d) Determine an expression for the approximate amount of mechanical energy dissipated, ΔE , due to air resistance during the time the stack falls a distance y , where $y > Y$. Express your answer in terms of y , m , v_T , and fundamental constants.

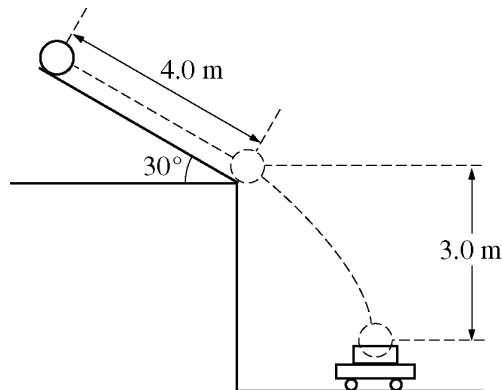

Note: Figure not drawn to scale.

Mech. 2.

A bowling ball of mass 6.0 kg is released from rest from the top of a slanted roof that is 4.0 m long and angled at 30° , as shown above. The ball rolls along the roof without slipping. The rotational inertia of a sphere of mass M and radius R about its center of mass is $\frac{2}{5}MR^2$.

- (a) On the figure below, draw and label the forces (not components) acting on the ball at their points of application as it rolls along the roof.

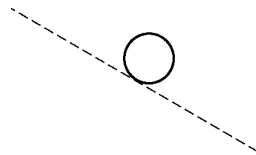

- (b) Calculate the force due to friction acting on the ball as it rolls along the roof. If you need to draw anything other than what you have shown in part (a) to assist in your solution, use the space below. Do NOT add anything to the figure in part (a).
- (c) Calculate the linear speed of the center of mass of the ball when it reaches the bottom edge of the roof.
- (d) A wagon containing a box is at rest on the ground below the roof so that the ball falls a vertical distance of 3.0 m and lands and sticks in the center of the box. The total mass of the wagon and the box is 12 kg. Calculate the horizontal speed of the wagon immediately after the ball lands in it.

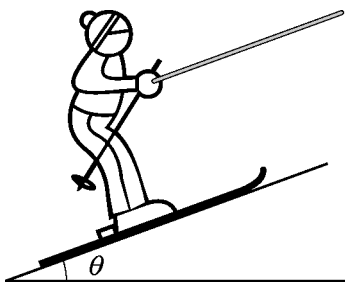

Mech. 3.

A skier of mass m will be pulled up a hill by a rope, as shown above. The magnitude of the acceleration of the skier as a function of time t can be modeled by the equations

$$a = a_{\max} \sin \frac{\pi t}{T} \quad (0 < t < T)$$

$$= 0 \quad (t \geq T),$$

where a_{\max} and T are constants. The hill is inclined at an angle θ above the horizontal, and friction between the skis and the snow is negligible. Express your answers in terms of given quantities and fundamental constants.

- Derive an expression for the velocity of the skier as a function of time during the acceleration. Assume the skier starts from rest.
- Derive an expression for the work done by the net force on the skier from rest until terminal speed is reached.
- Determine the magnitude of the force exerted by the rope on the skier at terminal speed.
- Derive an expression for the total impulse imparted to the skier during the acceleration.
- Suppose that the magnitude of the acceleration is instead modeled as $a = a_{\max} e^{-\pi t/2T}$ for all $t > 0$, where a_{\max} and T are the same as in the original model. On the axes below, sketch the graphs of the force exerted by the rope on the skier for the two models, from $t = 0$ to a time $t > T$. Label the original model F_1 and the new model F_2 .

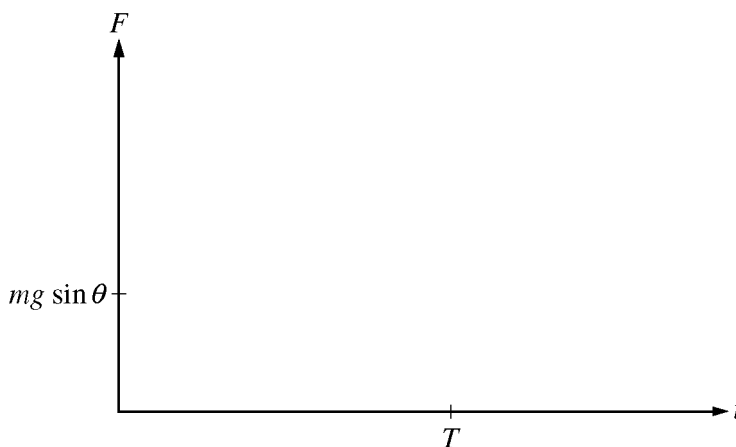

Physics C: Electricity and Magnetism Sample Multiple-Choice Questions

Most of the following sample questions have appeared in past exams. The answers are on page 77. Additional questions can be found in the *2009 AP Physics B and Physics C Released Exams* book.

Note: Units associated with numerical quantities are abbreviated, using the abbreviations listed in the table of information included with the exams (see insert in this book.)

Directions: Each of the questions or incomplete statements below is followed by five suggested answers or completions. Select the one that is best in each case.

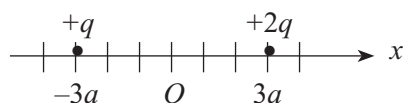

- Two charges are located on the x -axis of a coordinate system as shown above. The charge $+2q$ is located at $x = +3a$ and the charge $+q$ is located at $x = -3a$. Where on the x -axis should an additional charge $+4q$ be located to produce an electric field equal to zero at the origin O ?
 - $x = -6a$
 - $x = -2a$
 - $x = +a$
 - $x = +2a$
 - $x = +6a$

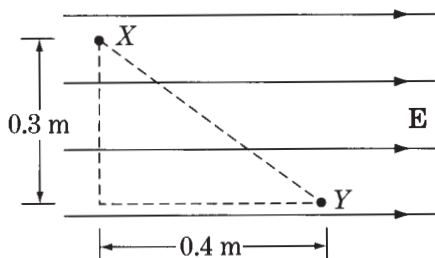

- A uniform electric field \mathbf{E} of magnitude $6,000 \text{ V/m}$ exists in a region of space as shown above. What is the electric potential difference, $V_X - V_Y$, between points X and Y ?
 - $-12,000 \text{ V}$
 - 0 V
 - $1,800 \text{ V}$
 - $2,400 \text{ V}$
 - $3,000 \text{ V}$

3. Charge is distributed uniformly throughout a long nonconducting cylinder of radius R . Which of the following graphs best represents the magnitude of the resulting electric field E as a function of r , the distance from the axis of the cylinder?

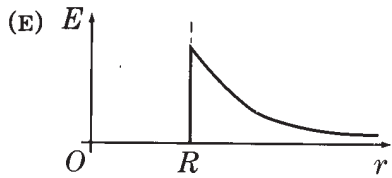
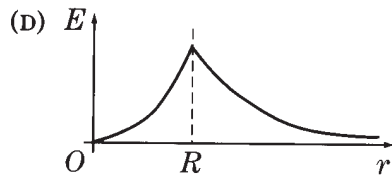
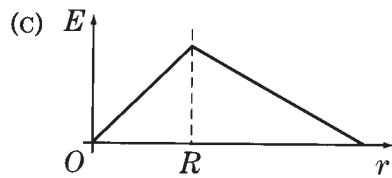
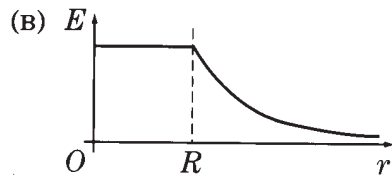
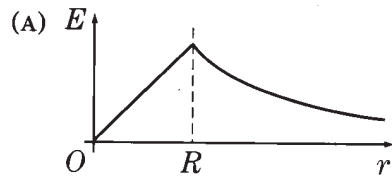

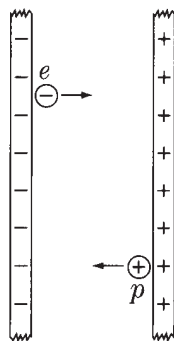

4. A proton p and an electron e are released simultaneously on opposite sides of an evacuated area between large, charged parallel plates, as shown above. Each particle is accelerated toward the oppositely charged plate. The particles are far enough apart so that they do not affect each other. Which particle has the greater kinetic energy upon reaching the oppositely charged plate?
- (A) The electron
 (B) The proton
 (C) Neither particle; both kinetic energies are the same.
 (D) It cannot be determined without knowing the value of the potential difference between the plates.
 (E) It cannot be determined without knowing the amount of charge on the plates.

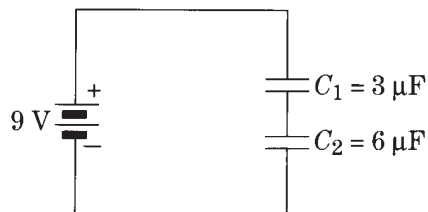

5. Two capacitors initially uncharged are connected in series to a battery, as shown above. What is the charge on the top plate of C_1 ?
- (A) $-81 \mu\text{C}$
 (B) $-18 \mu\text{C}$
 (C) $0 \mu\text{C}$
 (D) $+18 \mu\text{C}$
 (E) $+81 \mu\text{C}$

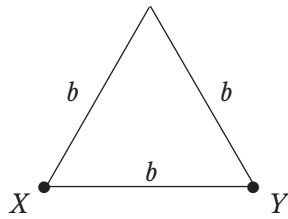

6. Wire of resistivity ρ and cross-sectional area A is formed into an equilateral triangle of side b , as shown above. The resistance between two vertices of the triangle, X and Y , is
- (A) $\frac{3}{2} \frac{A}{\rho b}$
 - (B) $3 \frac{A}{\rho b}$
 - (C) $\frac{2}{3} \frac{\rho b}{A}$
 - (D) $\frac{3}{2} \frac{\rho b}{A}$
 - (E) $3 \frac{\rho b}{A}$

Questions 7–8

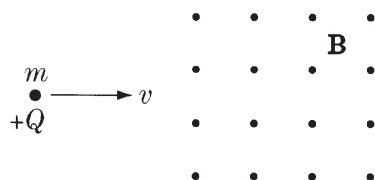

A particle of electric charge $+Q$ and mass m initially moves along a straight line in the plane of the page with constant speed v , as shown above. The particle enters a uniform magnetic field of magnitude B directed out of the page and moves in a semicircular arc of radius R .

7. Which of the following best indicates the magnitude and the direction of the magnetic force \mathbf{F} on the charge just after the charge enters the magnetic field?

<u>Magnitude</u>	<u>Direction</u>
(A) $\frac{kQ^2}{R^2}$	Toward the top of the page
(B) $\frac{kQ^2}{R^2}$	Toward the bottom of the page
(C) QvB	Out of the plane of the page
(D) QvB	Toward the top of the page
(E) QvB	Toward the bottom of the page

8. If the magnetic field strength is increased, which of the following will be true about the radius R ?

- I. R increases if the incident speed is held constant.
- II. For R to remain constant, the incident speed must be increased.
- III. For R to remain constant, the incident speed must be decreased.

- (A) I only
- (B) II only
- (C) III only
- (D) I and II only
- (E) I and III only

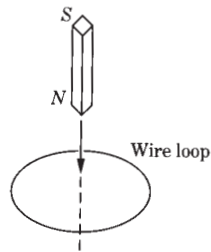

9. A bar magnet is lowered at constant speed through a loop of wire as shown in the diagram above. The time at which the midpoint of the bar magnet passes through the loop is t_1 . Which of the following graphs best represents the time dependence of the induced current in the loop? (A positive current represents a counterclockwise current in the loop as viewed from above.)

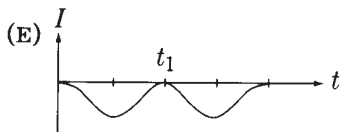
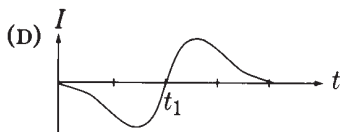
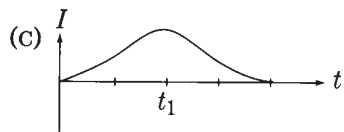
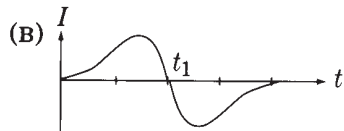
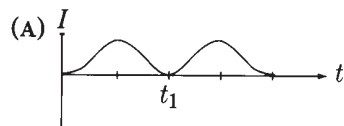

10. A loop of wire enclosing an area of 1.5 m^2 is placed perpendicular to a magnetic field. The field is given in teslas as a function of time t in seconds by

$$B(t) = \frac{20t}{3} - 5$$

The induced emf in the loop at $t = 3 \text{ s}$ is most nearly

- (A) 0 V
- (B) 5 V
- (C) 10 V
- (D) 15 V
- (E) 20 V

**Answers to Physics C: Electricity and Magnetism
Multiple-Choice Questions**

1 – A	3 – A	5 – D	7 – E	9 – B
2 – D	4 – C	6 – C	8 – B	10 – C

Physics C: Electricity and Magnetism Sample Free-Response Questions

PHYSICS C: ELECTRICITY AND MAGNETISM

SECTION II

Time—45 minutes

3 Questions

Directions: Answer all three questions. The suggested time is about 15 minutes for answering each of the questions, which are worth 15 points each. The parts within a question may not have equal weight. Show all your work in the pink booklet in the spaces provided after each part, NOT in this green insert.

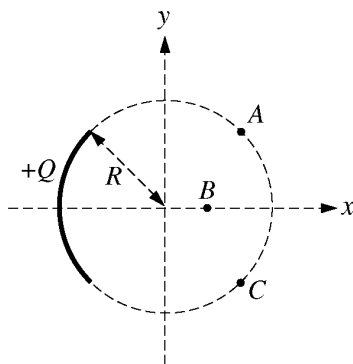

Figure I

E&M. 1.

A charge $+Q$ is uniformly distributed over a quarter circle of radius R , as shown above. Points A , B , and C are located as shown, with A and C located symmetrically relative to the x -axis. Express all algebraic answers in terms of the given quantities and fundamental constants.

- (a) Rank the magnitude of the electric potential at points A , B , and C from greatest to least, with number 1 being greatest. If two points have the same potential, give them the same ranking.

_____ V_A _____ V_B _____ V_C

Justify your rankings.

Point P is at the origin, as shown below, and is the center of curvature of the charge distribution.

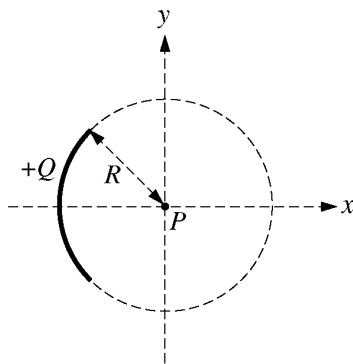
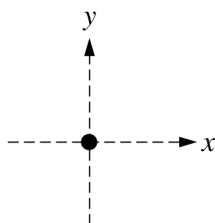
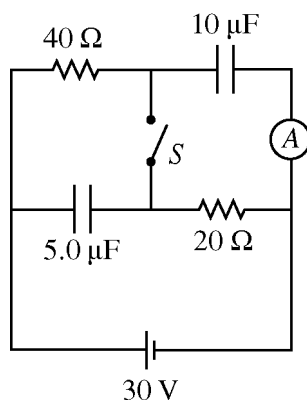

Figure II

- (b) Determine an expression for the electric potential at point P due to the charge Q .
- (c) A positive point charge q with mass m is placed at point P and released from rest. Derive an expression for the speed of the point charge when it is very far from the origin.
- (d) On the dot representing point P below, indicate the direction of the electric field at point P due to the charge Q .



- (e) Derive an expression for the magnitude of the electric field at point P .



E&M. 2.

In the circuit illustrated above, switch S is initially open and the battery has been connected for a long time.

- (a) What is the steady-state current through the ammeter?
- (b) Calculate the charge on the $10\ \mu\text{F}$ capacitor.
- (c) Calculate the energy stored in the $5.0\ \mu\text{F}$ capacitor.

The switch is now closed, and the circuit comes to a new steady state.

- (d) Calculate the steady-state current through the battery.
- (e) Calculate the final charge on the $5.0\ \mu\text{F}$ capacitor.
- (f) Calculate the energy dissipated as heat in the $40\ \Omega$ resistor in one minute once the circuit has reached steady state.

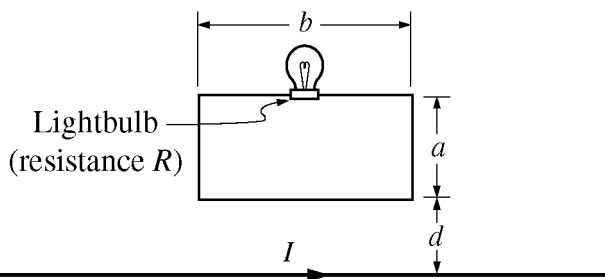

E&M. 3.

The long straight wire illustrated above carries a current I to the right. The current varies with time t according to the equation $I = I_0 - Kt$, where I_0 and K are positive constants and I remains positive throughout the time period of interest. The bottom of a rectangular loop of wire of width b and height a is located a distance d above the long wire, with the long wire in the plane of the loop as shown. A lightbulb with resistance R is connected in the loop. Express all algebraic answers in terms of the given quantities and fundamental constants.

- (a) Indicate the direction of the current in the loop.

Clockwise Counterclockwise

Justify your answer.

- (b) Indicate whether the lightbulb gets brighter, gets dimmer, or stays the same brightness over the time period of interest.

Gets brighter Gets dimmer Remains the same

Justify your answer.

- (c) Determine the magnetic field at $t = 0$ due to the current in the long wire at distance r from the long wire.
- (d) Derive an expression for the magnetic flux through the loop as a function of time.
- (e) Derive an expression for the power dissipated by the lightbulb.

Teacher Support

AP Central® (apcentral.collegeboard.com)

You can find the following Web resources at AP Central:

- AP Course Descriptions, AP Learning Objectives, information about the AP Course Audit, AP Exam questions and scoring guidelines, sample syllabi and feature articles.
- A searchable Institutes and Workshops database, providing information about professional development events.
- The Course Home Pages (apcentral.collegeboard.com/coursehomepages), which contain articles, teaching tips, activities, lab ideas and other course-specific content contributed by colleagues in the AP community.
- Moderated electronic discussion groups (EDGs) for each AP course, provided to facilitate the exchange of ideas and practices.

Additional Resources

Course Descriptions may be downloaded free of charge from AP Central; printed copies may be purchased through the College Board Store (store.collegeboard.com).

Course Audit Resources. For those looking for information on developing syllabi, the AP Course Audit website offers a host of valuable resources. Each subject has a syllabus development guide that includes the guidelines reviewers use to evaluate syllabi as well as multiple samples of evidence for each requirement. Four sample syllabi written by AP teachers and college faculty who teach the equivalent course at colleges and universities are also available. Along with a syllabus self-evaluation checklist and an example textbook list, a set of curricular/resource requirements is provided for each course that outlines the expectations that college faculty nationwide have established for college-level courses. Visit www.collegeboard.com/apcourseaudit for more information and to download these free resources.

Released Exams. Periodically the AP Program releases a complete copy of each exam. In addition to providing the multiple-choice questions and answers, the publication describes the process of scoring the free-response questions and includes examples of students' actual responses, the scoring standards and commentaries that explain why the responses received the scores they did. Released Exams are available at the College Board Store (store.collegeboard.com).

Additional, **free AP resources** are available to help students, parents, AP Coordinators and high school and college faculty learn more about the AP Program and its courses and exams. Visit www.collegeboard.com/apfreepubs for details.



Table of Information and Equation Tables for AP Physics Exams

The accompanying Table of Information and Equation Tables will be provided to students when they take the AP Physics Exams. Therefore, students may NOT bring their own copies of these tables to the exam room, although they may use them throughout the year in their classes in order to become familiar with their content. **Check the Physics course home pages on AP Central for the latest versions of these tables (apcentral.collegeboard.com).**

Table of Information

For both the Physics B and Physics C Exams, the Table of Information is printed near the front cover of the multiple-choice section and on the green insert provided with the free-response section. The tables are identical for both exams except for one convention as noted.

Equation Tables

For both the Physics B and Physics C Exams, the equation tables for each exam are printed only on the green insert provided with the free-response section. The equation tables may be used by students when taking the free-response sections of both exams but NOT when taking the multiple-choice sections.

The equations in the tables express the relationships that are encountered most frequently in AP Physics courses and exams. However, the tables do not include all equations that might possibly be used. For example, they do not include many equations that can be derived by combining other equations in the tables. Nor do they include equations that are simply special cases of any that are in the tables. Students are responsible for understanding the physical principles that underlie each equation and for knowing the conditions for which each equation is applicable.

The equation tables are grouped in sections according to the major content category in which they appear. Within each section, the symbols used for the variables in that section are defined. However, in some cases the same symbol is used to represent different quantities in different tables. It should be noted that there is no uniform convention among textbooks for the symbols used in writing equations. The equation tables follow many common conventions, but in some cases consistency was sacrificed for the sake of clarity.

Some explanations about notation used in the equation tables:

1. The symbols used for physical constants are the same as those in the Table of Information and are defined in the Table of Information rather than in the right-hand columns of the tables.
2. Symbols in bold face represent vector quantities.
3. Subscripts on symbols in the equations are used to represent special cases of the variables defined in the right-hand columns.
4. The symbol Δ before a variable in an equation specifically indicates a change in the variable (i.e., final value minus initial value).
5. Several different symbols (e.g., d , r , s , h , ℓ) are used for linear dimensions such as length. The particular symbol used in an equation is one that is commonly used for that equation in textbooks.

TABLE OF INFORMATION DEVELOPED FOR 2012 (see note on cover page)

CONSTANTS AND CONVERSION FACTORS	
Proton mass, $m_p = 1.67 \times 10^{-27}$ kg	Electron charge magnitude, $e = 1.60 \times 10^{-19}$ C
Neutron mass, $m_n = 1.67 \times 10^{-27}$ kg	1 electron volt, $1 \text{ eV} = 1.60 \times 10^{-19}$ J
Electron mass, $m_e = 9.11 \times 10^{-31}$ kg	Speed of light, $c = 3.00 \times 10^8$ m/s
Avogadro's number, $N_0 = 6.02 \times 10^{23}$ mol ⁻¹	Universal gravitational constant, $G = 6.67 \times 10^{-11}$ m ³ /kg·s ²
Universal gas constant, $R = 8.31$ J/(mol·K)	Acceleration due to gravity at Earth's surface, $g = 9.8$ m/s ²
Boltzmann's constant, $k_B = 1.38 \times 10^{-23}$ J/K	
1 unified atomic mass unit,	$1 \text{ u} = 1.66 \times 10^{-27}$ kg = 931 MeV/c ²
Planck's constant,	$h = 6.63 \times 10^{-34}$ J·s = 4.14 × 10 ⁻¹⁵ eV·s
	$hc = 1.99 \times 10^{-25}$ J·m = 1.24 × 10 ³ eV·nm
Vacuum permittivity,	$\epsilon_0 = 8.85 \times 10^{-12}$ C ² /N·m ²
Coulomb's law constant, $k = 1/4\pi\epsilon_0 = 9.0 \times 10^9$ N·m ² /C ²	
Vacuum permeability,	$\mu_0 = 4\pi \times 10^{-7}$ (T·m)/A
Magnetic constant, $k' = \mu_0/4\pi = 1 \times 10^{-7}$ (T·m)/A	
1 atmosphere pressure,	$1 \text{ atm} = 1.0 \times 10^5$ N/m ² = 1.0 × 10 ⁵ Pa

UNIT SYMBOLS	meter, m	mole, mol	watt, W	farad, F
	kilogram, kg	hertz, Hz	coulomb, C	tesla, T
	second, s	newton, N	volt, V	degree Celsius, °C
	ampere, A	pascal, Pa	ohm, Ω	electron-volt, eV
	kelvin, K	joule, J	henry, H	

PREFIXES		
Factor	Prefix	Symbol
10 ⁹	giga	G
10 ⁶	mega	M
10 ³	kilo	k
10 ⁻²	centi	c
10 ⁻³	milli	m
10 ⁻⁶	micro	μ
10 ⁻⁹	nano	n
10 ⁻¹²	pico	p

VALUES OF TRIGONOMETRIC FUNCTIONS FOR COMMON ANGLES							
θ	0°	30°	37°	45°	53°	60°	90°
$\sin \theta$	0	1/2	3/5	$\sqrt{2}/2$	4/5	$\sqrt{3}/2$	1
$\cos \theta$	1	$\sqrt{3}/2$	4/5	$\sqrt{2}/2$	3/5	1/2	0
$\tan \theta$	0	$\sqrt{3}/3$	3/4	1	4/3	$\sqrt{3}$	∞

The following conventions are used in this exam.

- I. Unless otherwise stated, the frame of reference of any problem is assumed to be inertial.
- II. The direction of any electric current is the direction of flow of positive charge (conventional current).
- III. For any isolated electric charge, the electric potential is defined as zero at an infinite distance from the charge.
- *IV. For mechanics and thermodynamics equations, W represents the work done on a system.

*Not on the Table of Information for Physics C, since Thermodynamics is not a Physics C topic.

ADVANCED PLACEMENT PHYSICS B EQUATIONS DEVELOPED FOR 2012

NEWTONIAN MECHANICS

$v = v_0 + at$	$a =$ acceleration
$x = x_0 + v_0t + \frac{1}{2}at^2$	$F =$ force
$v^2 = v_0^2 + 2a(x - x_0)$	$f =$ frequency
$\Sigma \mathbf{F} = \mathbf{F}_{net} = m\mathbf{a}$	$h =$ height
$F_{fric} \leq \mu N$	$J =$ impulse
$a_c = \frac{v^2}{r}$	$K =$ kinetic energy
$\tau = rF \sin \theta$	$k =$ spring constant
$\mathbf{p} = m\mathbf{v}$	$\ell =$ length
$\mathbf{J} = \mathbf{F}\Delta t = \Delta \mathbf{p}$	$m =$ mass
$K = \frac{1}{2}mv^2$	$N =$ normal force
$\Delta U_g = mgh$	$P =$ power
$W = F\Delta r \cos \theta$	$p =$ momentum
$P_{avg} = \frac{W}{\Delta t}$	$r =$ radius or distance
$P = Fv \cos \theta$	$T =$ period
$\mathbf{F}_s = -k\mathbf{x}$	$t =$ time
$U_s = \frac{1}{2}kx^2$	$U =$ potential energy
$T_s = 2\pi\sqrt{\frac{m}{k}}$	$v =$ velocity or speed
$T_p = 2\pi\sqrt{\frac{\ell}{g}}$	$W =$ work done on a system
$T = \frac{1}{f}$	$x =$ position
$F_G = -\frac{Gm_1m_2}{r^2}$	$\mu =$ coefficient of friction
$U_G = -\frac{Gm_1m_2}{r}$	$\theta =$ angle
	$\tau =$ torque

ELECTRICITY AND MAGNETISM

$F = \frac{kq_1q_2}{r^2}$	$A =$ area
$\mathbf{E} = \frac{\mathbf{F}}{q}$	$B =$ magnetic field
$U_E = qV = \frac{kq_1q_2}{r}$	$C =$ capacitance
$E_{avg} = -\frac{V}{d}$	$d =$ distance
$V = k\left(\frac{q_1}{r_1} + \frac{q_2}{r_2} + \frac{q_3}{r_3} + \dots\right)$	$E =$ electric field
$C = \frac{Q}{V}$	$\mathcal{E} =$ emf
$C = \frac{\epsilon_0 A}{d}$	$F =$ force
$U_c = \frac{1}{2}QV = \frac{1}{2}CV^2$	$I =$ current
$I_{avg} = \frac{\Delta Q}{\Delta t}$	$\ell =$ length
$R = \frac{\rho \ell}{A}$	$P =$ power
$V = IR$	$Q =$ charge
$P = IV$	$q =$ point charge
$C_p = C_1 + C_2 + C_3 + \dots$	$R =$ resistance
$\frac{1}{C_s} = \frac{1}{C_1} + \frac{1}{C_2} + \frac{1}{C_3} + \dots$	$r =$ distance
$R_s = R_1 + R_2 + R_3 + \dots$	$t =$ time
$\frac{1}{R_p} = \frac{1}{R_1} + \frac{1}{R_2} + \frac{1}{R_3} + \dots$	$U =$ potential (stored) energy
$F_B = qvB \sin \theta$	$V =$ electric potential or potential difference
$F_B = BI\ell \sin \theta$	$v =$ velocity or speed
$B = \frac{\mu_0 I}{2\pi r}$	$\rho =$ resistivity
$\phi_m = BA \cos \theta$	$\theta =$ angle
$\mathcal{E}_{avg} = -\frac{\Delta \phi_m}{\Delta t}$	$\phi_m =$ magnetic flux
$\mathcal{E} = B\ell v$	

ADVANCED PLACEMENT PHYSICS B EQUATIONS DEVELOPED FOR 2012

FLUID MECHANICS AND THERMAL PHYSICS

$\rho = m/V$ $P = P_0 + \rho gh$ $F_{buoy} = \rho Vg$ $A_1 v_1 = A_2 v_2$ $P + \rho gy + \frac{1}{2} \rho v^2 = \text{const.}$ $\Delta \ell = \alpha \ell_0 \Delta T$ $H = \frac{kA\Delta T}{L}$ $P = \frac{F}{A}$ $PV = nRT = Nk_B T$ $K_{avg} = \frac{3}{2} k_B T$ $v_{rms} = \sqrt{\frac{3RT}{M}} = \sqrt{\frac{3k_B T}{\mu}}$ $W = -P\Delta V$ $\Delta U = Q + W$ $e = \left \frac{W}{Q_H} \right $ $e_c = \frac{T_H - T_C}{T_H}$	$A = \text{area}$ $e = \text{efficiency}$ $F = \text{force}$ $h = \text{depth}$ $H = \text{rate of heat transfer}$ $k = \text{thermal conductivity}$ $K_{avg} = \text{average molecular kinetic energy}$ $\ell = \text{length}$ $L = \text{thickness}$ $m = \text{mass}$ $M = \text{molar mass}$ $n = \text{number of moles}$ $N = \text{number of molecules}$ $P = \text{pressure}$ $Q = \text{heat transferred to a system}$ $T = \text{temperature}$ $U = \text{internal energy}$ $V = \text{volume}$ $v = \text{velocity or speed}$ $v_{rms} = \text{root-mean-square velocity}$ $W = \text{work done on a system}$ $y = \text{height}$ $\alpha = \text{coefficient of linear expansion}$ $\mu = \text{mass of molecule}$ $\rho = \text{density}$
--	---

ATOMIC AND NUCLEAR PHYSICS

$E = hf = pc$ $K_{max} = hf - \phi$ $\lambda = \frac{h}{p}$ $\Delta E = (\Delta m)c^2$	$E = \text{energy}$ $f = \text{frequency}$ $K = \text{kinetic energy}$ $m = \text{mass}$ $p = \text{momentum}$ $\lambda = \text{wavelength}$ $\phi = \text{work function}$
--	--

WAVES AND OPTICS

$v = f\lambda$ $n = \frac{c}{v}$ $n_1 \sin \theta_1 = n_2 \sin \theta_2$ $\sin \theta_c = \frac{n_2}{n_1}$ $\frac{1}{s_i} + \frac{1}{s_o} = \frac{1}{f}$ $M = \frac{h_i}{h_o} = -\frac{s_i}{s_o}$ $f = \frac{R}{2}$ $d \sin \theta = m\lambda$ $x_m \approx \frac{m\lambda L}{d}$	$d = \text{separation}$ $f = \text{frequency or focal length}$ $h = \text{height}$ $L = \text{distance}$ $M = \text{magnification}$ $m = \text{an integer}$ $n = \text{index of refraction}$ $R = \text{radius of curvature}$ $s = \text{distance}$ $v = \text{speed}$ $x = \text{position}$ $\lambda = \text{wavelength}$ $\theta = \text{angle}$
---	--

GEOMETRY AND TRIGONOMETRY

<p>Rectangle $A = bh$</p> <p>Triangle $A = \frac{1}{2}bh$</p> <p>Circle $A = \pi r^2$ $C = 2\pi r$</p> <p>Rectangular Solid $V = \ell wh$</p> <p>Cylinder $V = \pi r^2 \ell$ $S = 2\pi r \ell + 2\pi r^2$</p> <p>Sphere $V = \frac{4}{3}\pi r^3$ $S = 4\pi r^2$</p> <p>Right Triangle $a^2 + b^2 = c^2$ $\sin \theta = \frac{a}{c}$ $\cos \theta = \frac{b}{c}$ $\tan \theta = \frac{a}{b}$</p>	$A = \text{area}$ $C = \text{circumference}$ $V = \text{volume}$ $S = \text{surface area}$ $b = \text{base}$ $h = \text{height}$ $\ell = \text{length}$ $w = \text{width}$ $r = \text{radius}$
---	--

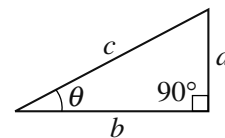

ADVANCED PLACEMENT PHYSICS C EQUATIONS DEVELOPED FOR 2012

MECHANICS

$v = v_0 + at$	$a =$ acceleration
$x = x_0 + v_0t + \frac{1}{2}at^2$	$F =$ force
$v^2 = v_0^2 + 2a(x - x_0)$	$f =$ frequency
$\Sigma \mathbf{F} = \mathbf{F}_{net} = m\mathbf{a}$	$h =$ height
$\mathbf{F} = \frac{d\mathbf{p}}{dt}$	$I =$ rotational inertia
$\mathbf{J} = \int \mathbf{F} dt = \Delta \mathbf{p}$	$J =$ impulse
$\mathbf{p} = m\mathbf{v}$	$K =$ kinetic energy
$F_{fric} \leq \mu N$	$k =$ spring constant
$W = \int \mathbf{F} \cdot d\mathbf{r}$	$\ell =$ length
$K = \frac{1}{2}mv^2$	$L =$ angular momentum
$P = \frac{dW}{dt}$	$m =$ mass
$P = \mathbf{F} \cdot \mathbf{v}$	$N =$ normal force
$\Delta U_g = mgh$	$P =$ power
$a_c = \frac{v^2}{r} = \omega^2 r$	$p =$ momentum
$\boldsymbol{\tau} = \mathbf{r} \times \mathbf{F}$	$r =$ radius or distance
$\Sigma \boldsymbol{\tau} = \boldsymbol{\tau}_{net} = I\boldsymbol{\alpha}$	$\mathbf{r} =$ position vector
$I = \int r^2 dm = \Sigma mr^2$	$T =$ period
$\mathbf{r}_{cm} = \Sigma m\mathbf{r} / \Sigma m$	$t =$ time
$v = r\omega$	$U =$ potential energy
$\mathbf{L} = \mathbf{r} \times \mathbf{p} = I\boldsymbol{\omega}$	$v =$ velocity or speed
$K = \frac{1}{2}I\omega^2$	$W =$ work done on a system
$\omega = \omega_0 + \alpha t$	$x =$ position
$\theta = \theta_0 + \omega_0 t + \frac{1}{2}\alpha t^2$	$\mu =$ coefficient of friction
	$\theta =$ angle
	$\tau =$ torque
	$\omega =$ angular speed
	$\alpha =$ angular acceleration
	$\phi =$ phase angle
	$\mathbf{F}_s = -k\mathbf{x}$
	$U_s = \frac{1}{2}kx^2$
	$x = x_{max} \cos(\omega t + \phi)$
	$T = \frac{2\pi}{\omega} = \frac{1}{f}$
	$T_s = 2\pi\sqrt{\frac{m}{k}}$
	$T_p = 2\pi\sqrt{\frac{\ell}{g}}$
	$\mathbf{F}_G = -\frac{Gm_1m_2}{r^2}\hat{\mathbf{r}}$
	$U_G = -\frac{Gm_1m_2}{r}$

ELECTRICITY AND MAGNETISM

$F = \frac{1}{4\pi\epsilon_0} \frac{q_1q_2}{r^2}$	$A =$ area
$\mathbf{E} = \frac{\mathbf{F}}{q}$	$B =$ magnetic field
$\oint \mathbf{E} \cdot d\mathbf{A} = \frac{Q}{\epsilon_0}$	$C =$ capacitance
$E = -\frac{dV}{dr}$	$d =$ distance
$V = \frac{1}{4\pi\epsilon_0} \sum_i \frac{q_i}{r_i}$	$E =$ electric field
$U_E = qV = \frac{1}{4\pi\epsilon_0} \frac{q_1q_2}{r}$	$\mathcal{E} =$ emf
$C = \frac{Q}{V}$	$F =$ force
$C = \frac{\kappa\epsilon_0 A}{d}$	$I =$ current
$C_p = \sum_i C_i$	$J =$ current density
$\frac{1}{C_s} = \sum_i \frac{1}{C_i}$	$L =$ inductance
$I = \frac{dQ}{dt}$	$\ell =$ length
$U_c = \frac{1}{2}QV = \frac{1}{2}CV^2$	$n =$ number of loops of wire per unit length
$R = \frac{\rho\ell}{A}$	$N =$ number of charge carriers per unit volume
$\mathbf{E} = \rho\mathbf{J}$	$P =$ power
$I = Nev_d A$	$Q =$ charge
$V = IR$	$q =$ point charge
$R_s = \sum_i R_i$	$R =$ resistance
$\frac{1}{R_p} = \sum_i \frac{1}{R_i}$	$r =$ distance
$P = IV$	$t =$ time
$\mathbf{F}_M = q\mathbf{v} \times \mathbf{B}$	$U =$ potential or stored energy
	$V =$ electric potential
	$v =$ velocity or speed
	$\rho =$ resistivity
	$\phi_m =$ magnetic flux
	$\kappa =$ dielectric constant
	$\oint \mathbf{B} \cdot d\boldsymbol{\ell} = \mu_0 I$
	$d\mathbf{B} = \frac{\mu_0}{4\pi} \frac{I d\boldsymbol{\ell} \times \mathbf{r}}{r^3}$
	$\mathbf{F} = \int I d\boldsymbol{\ell} \times \mathbf{B}$
	$B_s = \mu_0 nI$
	$\phi_m = \int \mathbf{B} \cdot d\mathbf{A}$
	$\mathcal{E} = \oint \mathbf{E} \cdot d\boldsymbol{\ell} = -\frac{d\phi_m}{dt}$
	$\mathcal{E} = -L \frac{dI}{dt}$
	$U_L = \frac{1}{2}LI^2$

ADVANCED PLACEMENT PHYSICS C EQUATIONS DEVELOPED FOR 2012

GEOMETRY AND TRIGONOMETRY

Rectangle

$$A = bh$$

Triangle

$$A = \frac{1}{2}bh$$

Circle

$$A = \pi r^2$$

$$C = 2\pi r$$

Rectangular Solid

$$V = \ell wh$$

Cylinder

$$V = \pi r^2 \ell$$

$$S = 2\pi r \ell + 2\pi r^2$$

Sphere

$$V = \frac{4}{3}\pi r^3$$

$$S = 4\pi r^2$$

Right Triangle

$$a^2 + b^2 = c^2$$

$$\sin \theta = \frac{a}{c}$$

$$\cos \theta = \frac{b}{c}$$

$$\tan \theta = \frac{a}{b}$$

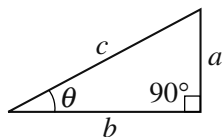

CALCULUS

$$\frac{df}{dx} = \frac{df}{du} \frac{du}{dx}$$

$$\frac{d}{dx}(x^n) = nx^{n-1}$$

$$\frac{d}{dx}(e^x) = e^x$$

$$\frac{d}{dx}(\ln x) = \frac{1}{x}$$

$$\frac{d}{dx}(\sin x) = \cos x$$

$$\frac{d}{dx}(\cos x) = -\sin x$$

$$\int x^n dx = \frac{1}{n+1}x^{n+1}, n \neq -1$$

$$\int e^x dx = e^x$$

$$\int \frac{dx}{x} = \ln|x|$$

$$\int \cos x dx = \sin x$$

$$\int \sin x dx = -\cos x$$

Contact Us

AP Services

P.O. Box 6671
Princeton, NJ 08541-6671
609-771-7300
888-225-5427 (toll free in the U.S. and Canada)
610-290-8979 (Fax)
E-mail: apexams@info.collegeboard.org

National Office

45 Columbus Avenue
New York, NY 10023-6992
212-713-8000

AP Canada Office

2950 Douglas Street, Suite 550
Victoria, BC, Canada V8T 4N4
250-472-8561
800-667-4548 (toll free in Canada only)
E-mail: gewonus@ap.ca

International Services

Serving all countries outside the U.S. and Canada
45 Columbus Avenue
New York, NY 10023-6992
212-373-8738
E-mail: international@collegeboard.org

Middle States Regional Office

Serving Delaware, District of Columbia, Maryland, New Jersey, New York, Pennsylvania, Puerto Rico and the U.S. Virgin Islands
Three Bala Plaza East
Suite 501
Bala Cynwyd, PA 19004-1501
610-227-2550
866-392-3019
610-227-2580 (Fax)
E-mail: msro@info.collegeboard.org

Midwestern Regional Office

Serving Illinois, Indiana, Iowa, Kansas, Michigan, Minnesota, Missouri, Nebraska, North Dakota, Ohio, South Dakota, West Virginia and Wisconsin
6111 N. River Road, Suite 550
Rosemont, IL 60018-5158
866-392-4086
847-653-4528 (Fax)
E-mail: mro@info.collegeboard.org

New England Regional Office

Serving Connecticut, Maine, Massachusetts, New Hampshire, Rhode Island and Vermont
1601 Trapelo Road, Suite 12
Waltham, MA 02451-1982
866-392-4089
781-663-2743 (Fax)
E-mail: nero@info.collegeboard.org

Southern Regional Office

Serving Alabama, Florida, Georgia, Kentucky, Louisiana, Mississippi, North Carolina, South Carolina, Tennessee and Virginia
3700 Crestwood Parkway NW, Suite 700
Duluth, GA 30096-7155
866-392-4088
770-225-4062 (Fax)
E-mail: sro@info.collegeboard.org

Southwestern Regional Office

Serving Arkansas, New Mexico, Oklahoma and Texas
4330 Gaines Ranch Loop, Suite 200
Austin, TX 78735-6735
866-392-3017
512-721-1841 (Fax)
E-mail: swro@info.collegeboard.org

Western Regional Office

Serving Alaska, Arizona, California, Colorado, Hawaii, Idaho, Montana, Nevada, Oregon, Utah, Washington and Wyoming
2099 Gateway Place, Suite 550
San Jose, CA 95110-1051
866-392-4078
408-367-1459 (Fax)
E-mail: wro@info.collegeboard.org

